



YKA  
SKA

YKE  
SKE

YKB  
SKB

YKC  
SKC

YKD  
SKD

## Wire Rope Hoists

### Operation & Service Manual

en-US

**Before installing hoist, fill in the information below.  
Refer to the Hoist and Motor data plates.**

Model No. \_\_\_\_\_

Serial No. \_\_\_\_\_

Purchase Date \_\_\_\_\_

Voltage \_\_\_\_\_

Rated Load \_\_\_\_\_

**Follow all instructions and warnings for inspecting, maintaining and operating this hoist.**

The use of any hoist presents some risk of personal injury or property damage. That risk is greatly increased if proper instructions and warnings are not followed. Before using this hoist, each operator should become thoroughly familiar with all warnings, **instructions and recommendations in this manual. Retain this manual for future reference and use.**

Forward this manual to operator. Failure to operate equipment as directed in manual may cause injury.

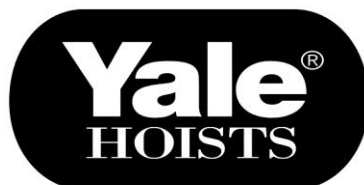

## **YALE/SHAWBOX HOIST PARTS AND SERVICES ARE AVAILABLE IN THE UNITED STATES AND IN CANADA**

As a Yale/Shawbox Hoist and Trolley user you are assured of reliable repair and parts services through a network of Master Parts Depots and Service Centers that are strategically located in the United States and Canada. These facilities have been selected on the basis of their demonstrated ability to handle all parts and repair requirements promptly and efficiently. To quickly obtain the name of the Master Parts Depot or Service Center located nearest you, call (800) 888-0985, Fax: (716) 689-5644, visit [www.cmworks.com](http://www.cmworks.com)

## **LAS PIEZAS Y REPARACIONES DE LOS POLIPASTOS DE YALE/SHAWBOX ESTÁN ASEGURADAS EN ESTADOS UNIDOS Y CANADÁ**

Como usuario de un polipasto y carro de Yale/Shawbox le aseguramos cualquier reparación o la disponibilidad de cualquier pieza de repuesto a través de una red de almacenes de piezas de repuesto y centros de servicio situados estratégicamente en Estados Unidos y Canadá. Estas instalaciones se han seleccionado en base a su capacidad demostrada en la reparación de equipos y suministro de piezas de repuesto de forma rápida y eficaz. Para obtener la dirección del almacén de piezas de repuesto o del centro de servicio más cercano, llame al teléfono (800) 888-0985. Fax: (716) 689-5644, visite [www.cmworks.com](http://www.cmworks.com) (sólo en Estados Unidos y Canadá).

## **LE SERVICE DE RÉPARATION ET DE PIÈCES POUR PALANS YALE/SHAWBOX EST DISPONIBLE AUX ÉTATS-UNIS ET AU CANADA**

Soyez assurés qu'en temps d'utilisateur de palan et treuil Yale/Shawbox, d'un service de réparation et de pièces fiable par l'entremise d'un réseau de Centres de service et de Dépôts de pièces maîtresses qui sont stratégiquement situés aux États-Unis et au Canada. Ces établissements ont été sélectionnés sur une base de leur habileté démontrée à s'occuper promptement et efficacement des besoins de réparation de pièces. Appelez le (800) 888-0985, Fax: (716) 689-5644, visite [www.cmworks.com](http://www.cmworks.com) pour obtenir rapidement le nom du dépôt de pièces maîtresses ou du centre de service situé le plus près.

# Contents

<b>1</b>	<b>General information .....</b>	<b>6</b>
<b>1.1</b>	<b>Information about safety messages .....</b>	<b>6</b>
	1.1.1 Explanation of signal words and symbols .....	6
	1.1.2 Safety instructions .....	6
	1.1.3 Section safety messages .....	6
	1.1.4 Embedded safety messages .....	6
	1.1.5 Safety alert symbols .....	7
	1.1.6 Additional symbol .....	7
<b>1.2</b>	<b>Spare parts.....</b>	<b>7</b>
<b>1.3</b>	<b>Target audience and responsibilities .....</b>	<b>7</b>
<b>1.4</b>	<b>Crane logbook.....</b>	<b>8</b>
<b>1.5</b>	<b>Transport and storage .....</b>	<b>8</b>
<b>1.6</b>	<b>Weight.....</b>	<b>8</b>
<b>1.7</b>	<b>Installation, commissioning, maintenance and repairs .....</b>	<b>8</b>
<b>1.8</b>	<b>After-sales service.....</b>	<b>9</b>
<b>1.9</b>	<b>Periodic inspections .....</b>	<b>9</b>
<b>1.10</b>	<b>Environmental information .....</b>	<b>9</b>
	1.10.1 Life cycle assessment .....	9
	1.10.2 Energy consumption .....	9
<b>2</b>	<b>General safety notes .....</b>	<b>10</b>
<b>2.1</b>	<b>Use for intended purpose .....</b>	<b>10</b>
<b>2.2</b>	<b>Inappropriate use.....</b>	<b>10</b>
<b>2.3</b>	<b>Residual hazards .....</b>	<b>11</b>
<b>2.4</b>	<b>Organizational safety precautions .....</b>	<b>11</b>
<b>2.5</b>	<b>General regulations.....</b>	<b>11</b>
<b>2.6</b>	<b>Recommended PPE .....</b>	<b>11</b>
<b>2.7</b>	<b>Working above floor level .....</b>	<b>12</b>
<b>2.8</b>	<b>Sound pressure level.....</b>	<b>12</b>
<b>2.9</b>	<b>Fire safety.....</b>	<b>12</b>
<b>2.10</b>	<b>Safety-conscious operation .....</b>	<b>13</b>
<b>2.11</b>	<b>Attaching load .....</b>	<b>13</b>
<b>3</b>	<b>Introduction .....</b>	<b>14</b>
<b>3.1</b>	<b>Incorporation .....</b>	<b>15</b>
<b>4</b>	<b>Installation.....</b>	<b>16</b>
<b>4.1</b>	<b>Stationary hoist.....</b>	<b>16</b>
	4.1.1 Attachment at bottom .....	17
	4.1.2 Attachment at top .....	19
<b>4.2</b>	<b>Fleet angle.....</b>	<b>20</b>
	4.2.1 Attachment at bottom .....	20
	4.2.2 Attachment at top .....	21
	4.2.3 Attachment at side .....	22
	4.2.4 Fleet angle .....	23
	4.2.5 Angle of installation .....	23
<b>4.3</b>	<b>Monorail trolleys .....</b>	<b>24</b>
	4.3.1 Monorail trolley (KE-S33 - 76) .....	24
	4.3.2 Drive shaft for travel drive (trolleys KE-S33 - KE-S65) .....	25
	4.3.3 Drive shaft for trolley drive (trolley KE-S76).....	26
	4.3.4 Monorail trolley (UE-S4).....	27
	4.3.5 Monorail trolley (UE-S776) .....	29
	4.3.6 Articulated trolley (DKE-S4 / DKE-S6) .....	31
<b>4.4</b>	<b>End stops for monorail trolleys .....</b>	<b>34</b>
<b>4.5</b>	<b>Double rail trolley (OE-S).....</b>	<b>35</b>
<b>4.6</b>	<b>End stops for double rail trolleys .....</b>	<b>36</b>
	4.6.1 Wheel diameter D = 3.9 in. ....	36
	4.6.2 Wheel diameter D = 4.9 - 7.9 in. ....	36
<b>4.7</b>	<b>Anti-jump catch.....</b>	<b>37</b>
	4.7.1 Description of system .....	37
	4.7.2 Procedure.....	37

4.8	Travel limit switches .....		40
	4.8.1	Monorail trolley.....	40
	4.8.2	Double rail trolley.....	40
4.9	Electrical equipment .....		41
	4.9.1	Supply cables.....	41
	4.9.2	Terminals.....	41
	4.9.3	Protection of equipment.....	42
	4.9.4	Emergency stop.....	42
	4.9.5	Runway conductor disconnecting means.....	42
	4.9.6	Disconnect switch.....	42
	4.9.7	Connection fuses.....	42
	4.9.8	Electromagnetic compatibility .....	43
	4.9.9	Overload safety device.....	44
	4.9.10	Connecting to mains.....	45
	4.9.11	Control and control functions.....	46
	4.9.12	Electric motors and related equipment .....	47
4.10	YK/SK hoists with frequency inverter (VFD) .....		47
4.11	Reeving rope .....		48
5	Commissioning.....		53
6	Operating.....		54
6.1	Operating precautions.....		54
6.2	Duties of crane operator.....		56
6.3	Using control pendant .....		57
6.4	Operating hoist with frequency inverter .....		58
6.5	Emergency stop.....		58
7	Inspection and maintenance .....		59
7.1	Inspection intervals.....		60
7.2	Maintenance intervals.....		61
7.3	Motors.....		62
7.4	Hoist motor brake (RSM).....		63
	7.4.1	Checking brake.....	63
	7.4.2	Replacing brake disk (brake rotor) .....	63
7.5	Hoist motor brake (NM) (pole-changing).....		64
	7.5.1	Checking brake.....	64
	7.5.2	Replacing brake disk (brake rotor) .....	64
7.6	Hoist motor brake (NM) (4-pole).....		65
	7.6.1	Checking brake.....	65
	7.6.2	Replacing brake disk (brake rotor) .....	65
7.7	Hoist motor brake (NM) 4HS.....		67
	7.7.1	Checking brake.....	67
	7.7.2	Replacing brake disk (brake rotor) .....	67
7.8	Travel motor brake .....		68
7.9	Hoist limit switch .....		69
	7.9.1	Hoist limit switch (standard) .....	69
7.10	Hoist limit switch .....		70
	7.10.1	Description of hoist limit switch system.....	70
	7.10.2	Testing emergency hoist limit switch, version 1 .....	70
	7.10.3	Testing operational hoist limit switch, version 1 .....	70
	7.10.4	Testing emergency hoist limit switch, version 2 .....	71
	7.10.5	Testing operational hoist limit switch, version 2 .....	71
	7.10.6	Setting hoist limit switch .....	72
	7.10.7	Servicing hoist limit switch .....	75
7.11	Hook dimensions C for KE-S.. trolleys.....		76
7.12	Overload safety device.....		77
	7.12.1	Testing overload safety device.....	77
	7.12.2	Maintenance of overload safety device with pressure sensor .....	77
	7.12.3	Maintenance of overload safety device with shear force sensor .....	77
7.13	Crane test.....		77
7.14	Rope drive.....		78
	7.14.1	Rope and rope attachment - general information .....	78
	7.14.2	Replacement of wire rope due to broken wires.....	79

	7.14.3	Removing rope guide .....	79
	7.14.4	Replacing wire rope.....	80
	7.14.5	Fitting rope guide .....	81
	7.14.6	Checking rope drum for wear .....	82
	7.14.7	Inspection and maintenance of rope sheave .....	83
	7.14.8	Checking load hook.....	84
7.15		<b>Trolley .....</b>	<b>85</b>
7.16		<b>Remaining service life .....</b>	<b>86</b>
	7.16.1	Operating hours counter in SLE load monitor .....	86
	7.16.2	SMC multi-controller (optional) .....	86
7.17		<b>General overhaul .....</b>	<b>86</b>
8		<b>Wearing parts .....</b>	<b>87</b>
8.1		<b>Serial number .....</b>	<b>87</b>
8.2		<b>Hoist .....</b>	<b>87</b>
9		<b>Troubleshooting .....</b>	<b>89</b>
10		<b>Decommissioning .....</b>	<b>91</b>
10.1		<b>Dismantling .....</b>	<b>91</b>
10.2		<b>Scrap disposal .....</b>	<b>91</b>
11		<b>Technical data .....</b>	<b>92</b>
11.1		<b>Conditions of use .....</b>	<b>92</b>
11.2		<b>Hoist .....</b>	<b>93</b>
	11.2.1	Pole-changing hoist motors ./...-MF 50Hz .....	93
	11.2.2	Pole-changing hoist motors ./...-MF 60Hz .....	94
	11.2.3	Pole-changing hoist motors 50Hz .....	95
	11.2.4	Pole-changing hoist motors 60Hz .....	95
	11.2.5	Frequency-controlled hoist motors ./4H.-MF 100 Hz.....	96
	11.2.6	Frequency-controlled hoist motors ./4H.-MF 120 Hz.....	96
	11.2.7	Frequency-controlled hoist motors ./4HS.-MF 100 Hz .....	97
	11.2.8	Frequency-controlled hoist motors ./4HS.-MF 120 Hz .....	97
11.3		<b>Cable cross sections and lengths of supply cable .....</b>	<b>98</b>
	11.3.1	Cable cross sections and lengths of supply cable for pole-changing hoist motors ...-MF .....	98
	11.3.2	Cable cross sections and lengths of supply cable for pole-changing hoist motors ..	98
11.4		<b>Tightening torques .....</b>	<b>99</b>
11.5		<b>Lubricants .....</b>	<b>101</b>
11.6		<b>Lubricants for travel drive .....</b>	<b>101</b>
11.7		<b>Circuit diagrams .....</b>	<b>101</b>

# 1 General information

---



## 1 General information

You have purchased a Yale product.  
This product was constructed in accordance with the applicable European standards and regulations.  
Read carefully and observe this manual. Store the manual within easy reach at the place of operation.

### 1.1 Information about safety messages

#### 1.1.1 Explanation of signal words and symbols

The following signal words are used in safety messages.

Signal word	Meaning
 <b>DANGER</b>	Indicates a hazardous situation which, if not avoided, will result in death or serious injury.
 <b>WARNING</b>	Indicates a hazardous situation which, if not avoided, could result in death or serious injury.
 <b>CAUTION</b>	Indicates a hazardous situation which, if not avoided, could result in minor or moderate injury.
<b>NOTICE</b>	Indicates possible material or environmental damage.

#### 1.1.2 Safety instructions

The fundamental hazards and required safety measures are listed in section “**General safety notes**”.

#### 1.1.3 Section safety messages

Section safety messages relate to an entire section and are laid out as follows.

##### **SIGNAL WORD**

Type and source of hazard  
Possible consequences if disregarded  
➤ Measures to prevent the hazard

---





#### 1.1.4 Embedded safety messages

Embedded safety messages are placed directly before or after a required action and are structured as follows.

 **SIGNAL WORD** Type and source of hazard, possible consequences if disregarded.  
➤ Measures to prevent the hazard,

# 1 General information

## 1.1.5 Safety alert symbols

Symbol	Meaning
	General hazard
	Electric shock hazard
	Falling parts hazard
	Suspended load hazard
	Hand injury hazard

## 1.1.6 Additional symbol

Symbol	Meaning
	Important note

## 1.2 Spare parts

### **WARNING**

**Safety hazard.** Incorrect or defective spare parts may lead to damage, malfunctions or the complete failure of the machine.

➤ Use only original spare parts.

## 1.3 Target audience and responsibilities

### **Owner**

Whoever uses and employs the product or has it operated by suitable trained personnel is considered to be the owner (employer/company).

### **Trained personnel**

Trained personnel are persons who have been instructed and trained in the duties with which they are entrusted and the risks which may arise from incorrect behavior, have been advised on the necessary protective devices, precautions, applicable regulations, accident prevention regulations and prevailing conditions and have proven their ability.

### **Qualified person**

A qualified person is a person who by possession of a recognized degree, certificate, or professional standing, or who by extensive knowledge, training, and experience, successfully demonstrates the ability to solve/resolve problems relating to the subject matter, the work, or the project.

### **Electrical qualified person**

An electrical qualified person is defined as:

One who has received training in and has demonstrated skills and knowledge in the construction and operation of electric equipment and installations and the hazard involved.

# 1 General information

## 1.4 Crane logbook

A completed crane logbook must be kept for each hoist. The results of the periodic inspections must be entered in the logbook.

## 1.5 Transport and storage

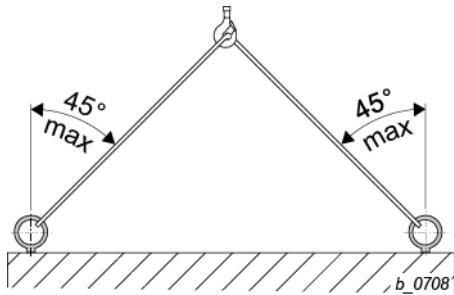

Fig. 1

### Transport

The product is delivered on a special pallet. This enables it to be loaded and unloaded safely with a fork-lift truck.

1. **⚠ WARNING Falling parts hazard.** If the product is to be transported suspended, attach the product to the sling points provided. The sling points are designed for a max. diagonal pull  $\geq 45^\circ$ .
2. Do not allow the hoist to drop. Set the product down on the ground correctly.
3. Avoid damage to the product and its components by loading and unloading it correctly.

### Storage

1. Store the product and its accessories in a dry place.
2. Store it in a stable position, secure it against toppling or overturning.
3. Observe environmental protection laws for storage (do not allow oil etc. to leak).
4. Make sure that the ground is firm and does not permit the machine to sink in.
5. Ensure the load is evenly distributed, support the hoist at several points.
6. Do not kink the ropes and avoid contact with the ground.

## 1.6 Weight

See factory certificate.

## 1.7 Installation, commissioning, maintenance and repairs

1. Make sure that installation, commissioning, maintenance and repairs are carried out by qualified persons only.
2. We recommend having installation carried out by qualified personnel engaged by the manufacturer.
3. Do not carry out any alterations or modifications.
4. Make sure that additional fitments are approved by the manufacturer. (During welding work, electrode and ground must be in contact with the same component!)
5. Use only original spare parts for repairs.
6. Make sure that dismantled guards are screwed down again and locked.

If the wire rope hoist is constantly operated out of doors and exposed to the elements without protection, we recommend fitting a canopy or at least "parking" the hoist under a roof.

- For detailed information about installation see section "**Installation**".
- For detailed information about commissioning see section "**Commissioning**".
- For detailed information and about maintenance and repairs see section "**Inspection and maintenance**".



# 1 General information

---

## 1.8 After-sales service

You have purchased a high-quality product. Our after sales service will give you advice on its correct use.

In order to maintain the safety and constant availability of the product, we recommend concluding a maintenance agreement.

### **Seminars:**

Comprehensive understanding of material handling products is a prerequisite for the correct use of equipment. Competent and practically oriented, we impart the specialist knowledge required for the correct use, monitoring and care of your system.

Ask for our seminar program.

## 1.9 Periodic inspections

- Hoists and cranes must be inspected by a qualified person least once a year, more frequently if so specified by national regulations.
- The results of the inspections must be recorded and filed in the test logbook.
- The remaining service life of the hoist must also be established during this inspection.
- The periodic inspections must be adapted to the hoist's use. Intensive use or adverse environmental conditions entail shorter maintenance intervals.

**All tests must always be initiated by the owner!**

## 1.10 Environmental information

Environmental aspects have been taken into account when developing and manufacturing this equipment. Please note the instructions on safe lubrication and waste disposal to avoid pollution risks during use. Appropriate use and correct maintenance will improve the environmental performance of this product.

### **1.10.1 Life cycle assessment**

The stages of the product service life are:

- Production of materials,
- components and energy,
- transport to factory,
- manufacture and assembly,
- transport to customer,
- on-site installation,
- operating phase including maintenance and modernization,
- dismantling and recycling of materials at end of service life.

### **1.10.2 Energy consumption**

The energy consumption during the operating phase has the highest impact on the environment. Electricity is required for starting and running the motors and for lighting, heating, cooling and other optional electrical components and parts of the hoist.

## 2 General safety notes

---

## 2 General safety notes



The products are constructed according to the state of the art and recognised safety rules. However, during use danger to the life and limb of the user or a third party can arise, or adverse effects can affect the product and other property.

### 2.1 Use for intended purpose

- Wire rope hoists are intended for lifting freely movable loads. Depending on their design, they are for stationary or mobile use.
- In the case of wire rope hoists with multiple load-bearing equipment, ensure that the load is distributed evenly between the falls.
- Any fundamental alterations and modifications to the product, such as e.g. welding on load-bearing components, structural alterations to load-bearing components, alteration of drives, alteration of speeds and motor outputs, replacing trolleys, etc. must be authorized by the manufacturer, otherwise the declaration of conformity/declaration of incorporation will be invalidated.
- Also any work on or additions to the control must be authorized by the manufacturer. The manufacturer cannot accept any liability for malfunctioning after unauthorized work on the control.
- The conditions in the place of use of the hoist must correspond to the operating conditions for which the hoist was designed (including indoor/outdoor use, ambient temperature, radiation temperature, wind, dust, splash water, snow, water, etc.
- For hoists which work in combination and have more than one control (tandem operation), action must be taken to coordinate the controls. This applies also to the reaction of the protective devices. Controls must be constructed accordingly.
- For hoists intended for automatic operation, the control must be designed accordingly.

### 2.2 Inappropriate use

- Use in areas with potentially explosive atmosphere.
- Transporting molten metal.
- Exceeding the maximum working load.
- Transporting persons.
- Pulling/towing or raising/lowering of a guided load.
- Using the hoist in applications in which the working load changes with the position of the load, as the hoist is not equipped with a load display and additional warning device when it cuts off at overload.
- Breaking away, pulling or towing of loads.
- Use of rope drive for “guided loads” without being designed for this type of application.
- Breaking away of tilted loads if the rope drive is designed for the “guided load” application.
- Pulling loads at an angle, dragging loads or moving vehicles with the load or load suspension equipment.
- Do not knot load ropes or chains or shorten them with devices such as bolts, screws or similar.
- Removing the safety latch from suspension and load hooks.
- Manipulating the overload safety device.
- Operation with slack rope (loose windings on the rope drum).
- If the product forms “part of a machine”, the person placing it on the market must ensure that the product meets the specific regulations of the application.

## 2 General safety notes

---

### 2.3 Residual hazards

The machine has been subjected to a risk analysis. The design and construction based on this correspond to the state of the art. However, residual hazards remain during operation and maintenance and these could result in serious or even fatal injuries to personnel.

- Risk of crushing
- Hazard due to falling parts (attached to the load or on the load)
- Load toppling due to unsuitable or damaged load-bearing equipment
- Risk of electric shock

#### Preventative measures:

1. Use LOTO (Lockout/Tagout) procedure in accordance to national, state and local regulations and company policy.
2. Switch the machine off and ensure it cannot be switched on again before carrying out maintenance, cleaning and repair work.
3. Switch off the power supply before all work on the electrical system. Check that the components to be replaced are free of current and voltage.
4. Do not remove any safety devices or override them by manipulating them.
5. When lifting or lowering loads ensure that no-one is in the immediate danger area.
6. It is forbidden for anyone to stand in the danger area.

### 2.4 Organizational safety precautions

- The owner may only employ insured persons to operate a crane single-handedly (crane operator), install or perform maintenance on the product if they are capable both physically and mentally,
- have been instructed in operating and maintaining the crane and have shown him proof of their competence and
- may be expected to perform the duties assigned them reliably.
- At regular intervals, check that work is being carried out in a safety-conscious manner.
- Observe the intervals specified for periodic inspections. File the test reports in the logbook.

### 2.5 General regulations

- Safety and accident prevention regulations.
- All national, state and local regulations.

### 2.6 Recommended PPE



Fig. 2

#### Personal protective equipment to be provided by the owner

- Safety shoes
- Gloves (only if there is no danger of them being drawn into equipment)
- Protective goggles
- Hart hat
- Hearing protection
- Closely fitting clothes (danger of clothing being drawn into equipment)
- When operating the hoist or standing close to the hoist, wire rope or chain there is a danger of fingers, clothing, jewelry, etc. being drawn into equipment

## 2 General safety notes

### 2.7 Working above floor level

Personnel must be protected from falling. Observe the national, state, and local regulations, and company policies when working above the floor level.

### 2.8 Sound pressure level

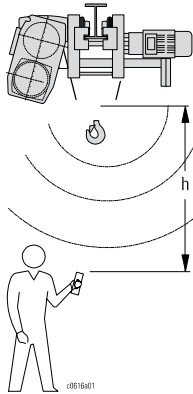
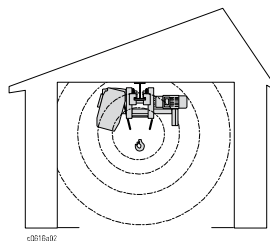

Fig. 3

The sound pressure level was measured at a distance of **3 ft** from the wire rope hoist. The mean sound pressure level is calculated for one operating cycle (50% with maximum permissible load, 50% without load).

Instead of stating an emission value based on a workplace, the values from Tab. 1 and Tab. 2 at measuring distance “h” can be used.



Wire rope hoist type	[db (A)] +/-3				
	h [ft]				
	3 ft	7 ft	13 ft	26 ft	52 ft
YKA/SKA	76	73	70	67	64
YKB/SKB	76	73	70	67	64
YKC/SKC	78	75	72	69	66
YKE/SKE	78	75	72	69	66

Tab. 1

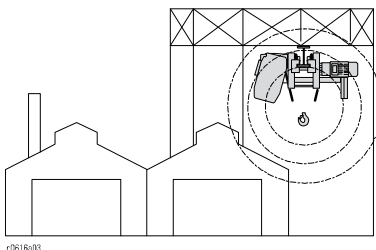

Fig. 4

Wire rope hoist type	[db (A)] +/-3				
	h [ft]				
	3 ft	7 ft	13 ft	26 ft	52 ft
YKA/SKA	76	70	64	58	52
YKB/SKB	76	70	64	58	52
YKC/SKC	78	72	66	60	50
YKE/SKE	78	72	66	60	50

Tab. 2

### 2.9 Fire safety

#### ⚠ WARNING

**Safety hazard.** Never use a powder extinguisher in the presence of high voltages. Only fight the fire if this is possible without subjecting yourself to risk. Switch off the crane if this is possible. Evacuate the area. Advise other persons on potential danger and call for help.

### 2.10 Safety-conscious operation

YK/SK wire rope hoists are constructed according to the state of the art and equipped with an overload safety device in standard version. In spite of this, dangers may arise from inappropriate use or use for an unintended purpose.

1. The owner is responsible for ensuring that work is carried out with safety in mind and avoiding risks.
2. Read the instructions before starting to work with the product.
3. Standing under a suspended load is forbidden. Danger to life and limb!
4. Observe the "Duties of crane operator".
5. Before starting work, find out where the emergency stop button is (usually in the control pendant).
6. Do not put your hand between edges which might crush or cut.
7. Do not grasp the moving rope.
8. Take note of the relevant instructions when attaching loads.
9. Do not stand between load and wall.
10. Start lifting the load carefully.
11. Never attempt to remedy a malfunction while the load is suspended.
12. Never use bent, open or distorted load hooks, or attempt to straighten them.
13. Have a damaged hook safety latch repaired.
14. Never anneal the hook.
15. Never lock the buttons of the control switch in place.
16. Never allow the load to drop into the hoist's load-bearing equipment.
17. Before lifting loads, ensure that the stated maximum working load is not exceeded.
18. When lifting and setting down loads, ensure that they are in a stable position in order to avoid accidents due to the load toppling or overturning.
19. Secure the load if the power is cut.
20. Do not kink or crush control cables.
21. Choose a safe place from which to operate the hoist.
22. Joining or mending ropes, chains or belts is not permitted.
23. Never touch metal components that are colder than 32°F or hotter than 131°F without wearing protective gloves.
24. Do not use the emergency limit switch (ultimate limit switch for highest and lowest hook position) as an operational limit switch.
25. Report damage and defects to the product (abnormal noises, impaired braking function, deformations, etc.) to the person responsible immediately. Do not use the product until the faults have been eliminated.
26. Do not remove information plates from the product. Replace illegible or damaged plates.
27. Have hoist inspected by the relevant authority before commissioning.

### 2.11 Attaching load

1. Use only tested and approved slings for attaching the load.
2. The hoist rope must not be wound around the load.
3. The load must always be suspended from the base of the hook. The tip of the hook must not be subjected to load.
4. Removing the safety latch from suspension and load hooks is not permitted.
5. Only attach hook block when stopped.
6. Hook or hook block turns under load – release the hook block and rope when lifting the load.
7. Do not reach into the hook block opening at the rope inlet – crushing hazard!
8. Guide the hook block on the load hook bracket - not on the hook base! – crushing hazard!

### 3 Introduction

### 3 Introduction

Wire rope hoists are intended for lifting freely movable loads.

The modular concept of our series of wire rope hoists permits a multitude of variations on the basis of series components.

The design is characterized by the rope drum and hoist motor being arranged in parallel. The hoist drive is a cylindrical rotor motor with a separately activated D.C. brake. Its design complies with the FEM calculation regulations which are adapted to the requirements of hoist operation.

The main components of the wire rope hoist are the hoist motor, the gear, the rope drum and the control box with connection parts.

Our certified quality assurance system to DIN ISO 9001 guarantees consistently high quality.

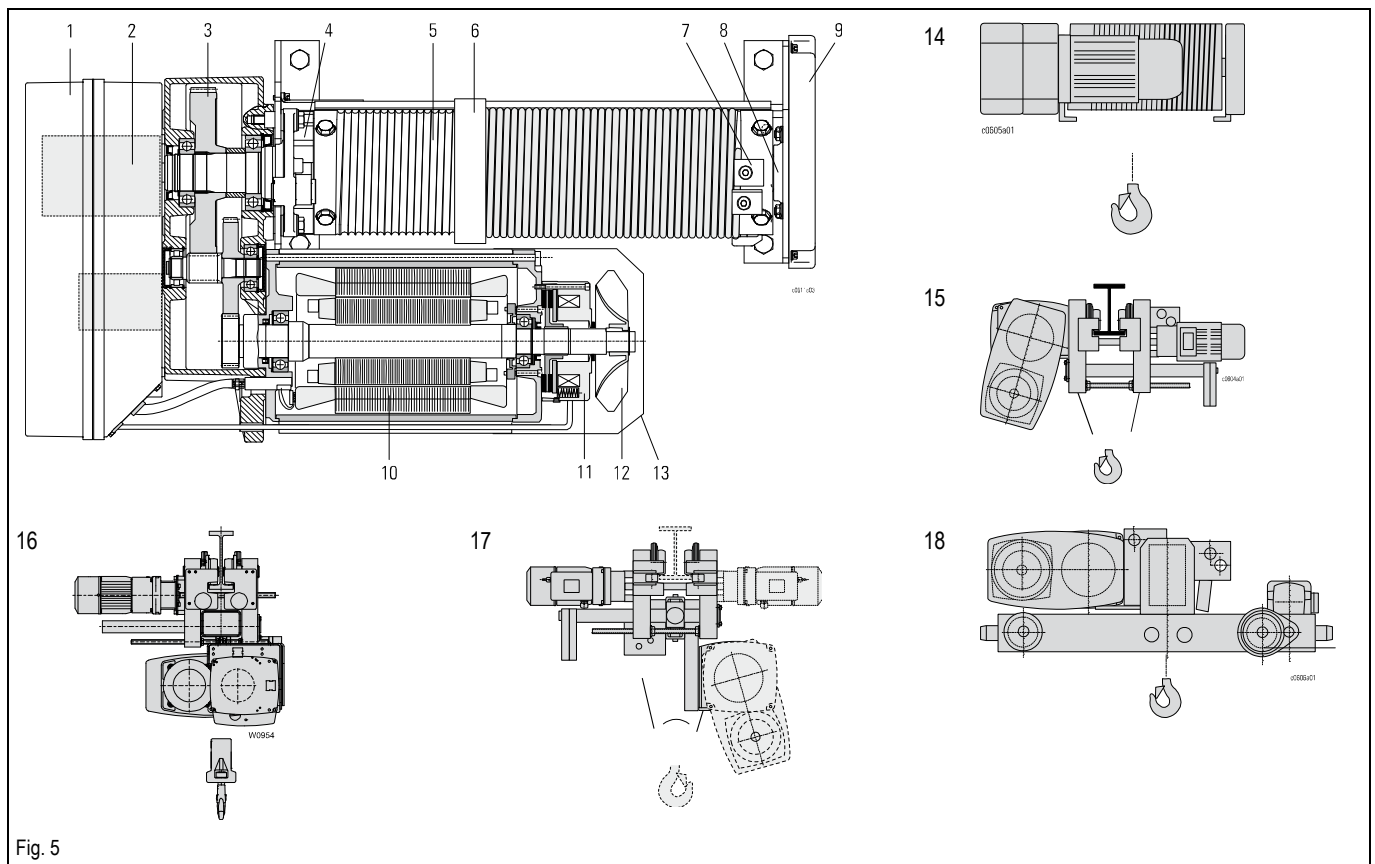

Fig. 5

- |   |  |
|---|--|
| 1 Panel box with connection parts                         | 2 Emergency hoist limit switch, operational hoist limit switch |
| 3 Gear  | 4 Mounting point for safety brake (YKB/SKB – YKE/SKE)          |
| 5 Rope drum   | 6 Rope guide with rope tensioning spring                       |
| 7 Clamps for rope attachment                              | 8 Rope drum bearing  |
| 9 End cover   | 10 Motor   |
| 11 Brake  | 12 Fan   |
| 13 Fan cover  | 14 Stationary wire rope hoist, hoist for incorporation         |
| 15 Wire rope hoist with “short headroom” monorail trolley | 16 Wire rope hoist with “standard headroom” monorail trolley   |
| 17 Wire rope hoist with “articulated” monorail trolley    | 18 Wire rope hoist with double rail trolley                    |

## 3 Introduction

---

### 3.1 Incorporation

#### **Stationary hoist (hoist for incorporation)**

The hoist is connected to a fixed structure by means of bolt joints permitting it to be attached to a base, wall or ceiling.

#### **Mobile hoist**

The hoists can be mounted on 4 different types of travel carriage.

## 4 Installation

### 4 Installation

#### 4.1 Stationary hoist

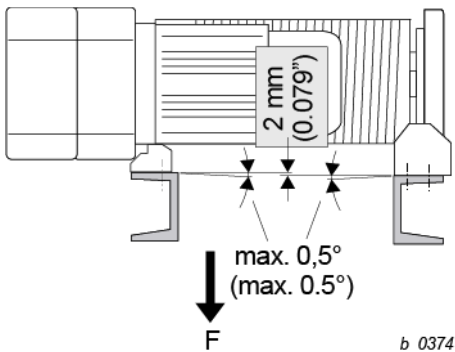

Fig. 6

Wire rope hoist type	$M_T$ (rope drum torque)
	[lb <sub>f</sub> in]
YKA/SKA	$\frac{1}{2} \times F \times 5$ in
YKB/SKB	$\frac{1}{2} \times F \times 6.6$ in
YKC/SKC	$\frac{1}{2} \times F \times 8.6$ in
YKE/SKE	$\frac{1}{2} \times F \times 14$ in

#### Possible mounting positions and fleet angles

Feet "at bottom" and "at top" are possible for designs with bottom hook block (rope lead-off vertically downwards).

The YK/SK wire rope hoist with 1PS and 1PS twin hook rope lead-off can be installed in various positions (fleet angles see page 20-23, section 4.2 "Fleet angle")

1. If possible, install the hoist in the **preferred installation position** \*\*\* (see page 20, section 4.2 1 "Attachment at bottom")
2. Use the fixing elements specified, see the following figures and tables.
3. Take care that no distortion arises from unevenness (**max. 0.5°, max. 0.079 in.**)
4. The customer's substructure must take up the torque  $M_T$  from the rope drum. It must therefore be torsion resistant.
5. If the rope lead-off is not vertical, the shearing forces arising must be taken up by a shear bar.
6. For tightening torques see page 102, section 11.4 "Tightening torques".

Standard reevings					
1PS	2PS	4PS	1PD	2PD	4PD

Fig. 7



## 4 Installation

### 4.1.1 Attachment at bottom

Ø17 mm  
(Ø0.67")

6× (1)  
12× (2)  
6× (3)

*b\_0375*

Type YKA/SKA		pcs
(1)	Screw M16-8.8	6
(2)	SCHNORR® Safety Washer S16	12
(3)	Nut, M16-8	6

Ø21 mm  
(Ø0.83")

6× (1)  
12× (2)  
6× (3)

*b\_0376*

Type YKB/SKB		pcs
(1)	Screw M20-8.8	6
(2)	SCHNORR® Safety Washer S20	12
(3)	Nut, M20-8	6

Ø25 mm  
(Ø0.98")

6× (1)  
12× (2)  
6× (3)

*b\_0377*

Type YKC/SKC		pcs
(1)	Nut, M24-8	6
(2)	SCHNORR® Safety Washer S24	12
(3)	Screw M24-8.8	6

Ø26 mm  
(Ø1.02")

6× (1)  
12× (2)  
6× (3)

*b\_0378*

Type YKE/SKE, YKD/SKD (2PS, 4PS, 2PD)		pcs
(1)	Screw M30-8.8	8
(2)	SCHNORR® Safety Washer S24	16
(3)	Nut, M30-8	8

## 4 Installation

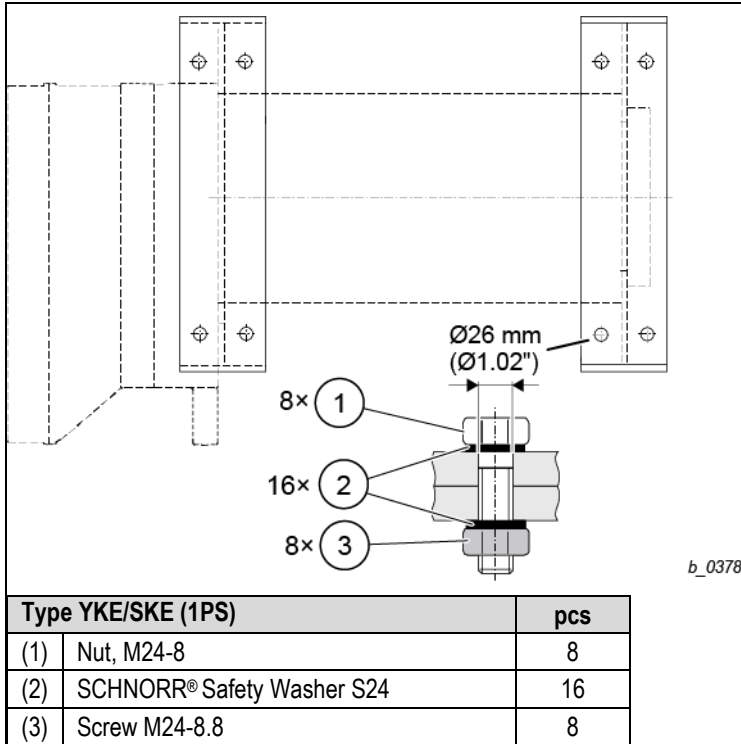

Fig. 8

## 4 Installation

### 4.1.2 Attachment at top

Ø17 mm  
(Ø0.67")

8× (1)  
16× (2)  
8× (3)

*b\_0363*

Type YKA/SKA		pcs
(1)	Nut, M16-8	8
(2)	SCHNORR® Safety Washer S16	16
(3)	Screw M16-8.8	8

Ø21 mm  
(Ø0.83")

8× (1)  
16× (2)  
8× (3)

*b\_0364*

Type YKB/SKB		pcs
(1)	Nut, M20-8	8
(2)	SCHNORR® Safety Washer S20	16
(3)	Screw M20-8.8	8

Ø25 mm  
(Ø0.98")

8× (1)  
16× (2)  
8× (3)

*b\_0365*

Type YKC/SKC		pcs
(1)	Nut, M24-8	8
(2)	SCHNORR® Safety Washer S24	16
(3)	Screw M24-8.8	8

Ø26 mm  
(Ø1.02")

8× (1)  
16× (2)  
8× (3)

*b\_0366*

Type YKE/SKE (1PS)		pcs
(1)	Screw M24-8.8	8
(2)	SCHNORR® Safety Washer S24	16
(3)	Nut, M24-8	8

Fig. 9

## 4 Installation

### 4.2 Fleet angle

#### 4.2.1 Attachment at bottom

Wire rope hoist types  
YKA/SKA, YKB/SKB, YKC/SKC, YKE/SKE

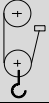
	 1PS, 1PS twin hook			
	YKA/ SKA	YKB/ SKB	YKC/ SKC	YKE/ SKE
$\alpha_1$	4°	5°	8°	8°
$\alpha_2$	23°	13°	20°	18°
$\alpha_3$	27°	30°	30°	30°
$\alpha_4$	74°	73°	76°	80°
$\alpha_5$	30°	30°	30°	25°
$\alpha_6$	113°	103°	110°	108°
$\alpha_7$	63°	61°	60°	60°
$\alpha_8$	11°	12°	16°	20°
$\alpha_9$	24°	26°	30°	-
$\alpha_{10}$	7°	7°	8°	8°
$\alpha_{12}$	90°	90°	90°	-

Tab. 3

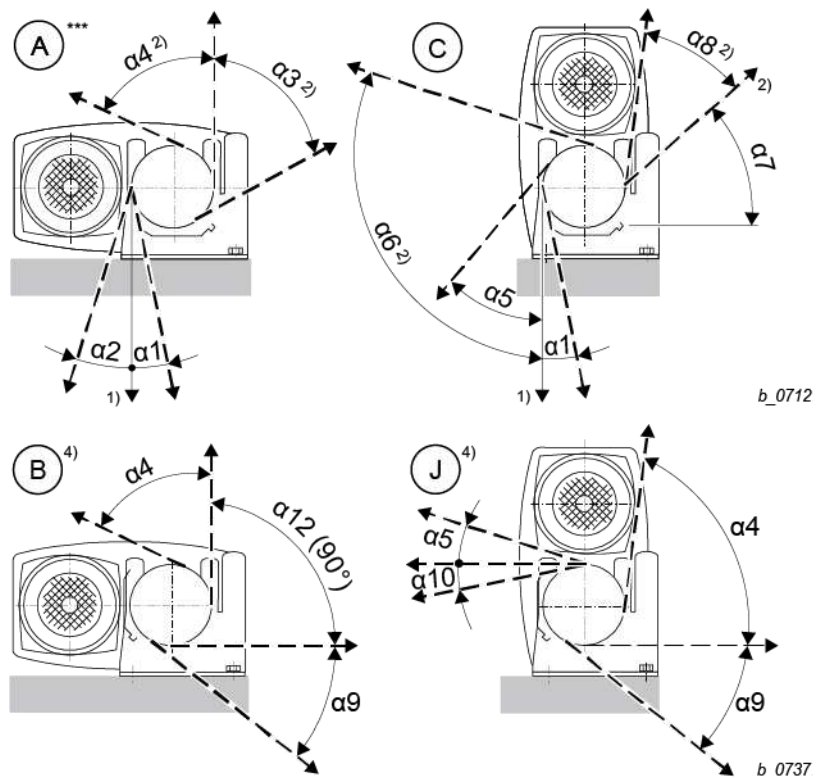

Fig. 10

\*\*\* Preferred installation position

- 1) Standard
- 2) By turning rope guide
- 4) By turning rope guide and grease pan.

**Type YKE/SKE:** Version (G) not possible

## 4 Installation

### 4.2.2 Attachment at top

Wire rope hoist types  
YKA/SKA, YKB/SKB, YKC/SKC, YKE/SKE

	 1PS, 1PS twin hook			
	YKA/ SKA	YKB/ SKB	YKC/ SKC	YKE/ SKE
$\alpha_1$	4°	5°	8°	on request
$\alpha_2$	23°	13°	20°	
$\alpha_3$	27°	30°	30°	
$\alpha_4$	74°	73°	76°	
$\alpha_5$	16°	17°	14°	
$\alpha_6$	35°	32°	36°	
$\alpha_7$	74°	74°	76°	
$\alpha_{12}$	90°	90°	90°	
$\alpha_{13}$	90°	90°	90°	

Tab. 4

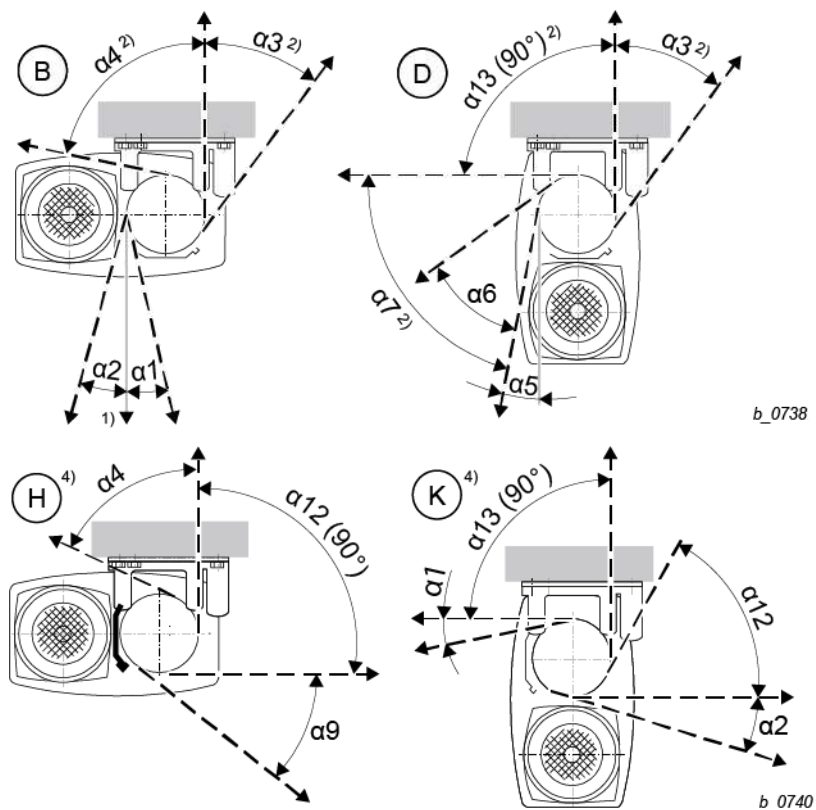



Fig. 11

- 1) Standard
  - 2) By turning rope guide
  - 4) By turning rope guide and grease pan.
- Type YKE/SKE:** Version (H) not possible

## 4 Installation

### 4.2.3 Attachment at side

Wire rope hoist types  
YKA/SKA, YKB/SKB, YKC/SKC, YKE/SKE

	 1PS, 1PS twin hook			
	YKA/ SKA	YKB/ SKB	YKC/ SKC	YKE/ SKE
$\alpha_1$	21°	23°	18°	on request
$\alpha_2$	12°	13°	20°	
$\alpha_3$	74°	73°	76°	
$\alpha_4$	10°	10°	20°	
$\alpha_5$	21°	23°	18°	
$\alpha_6$	23°	20°	20°	
$\alpha_7$	27°	30°	30°	
$\alpha_8$	74°	73°	76°	
$\alpha_9$	4°	5°	8°	
$\alpha_{10}$	23°	13°	20°	
$\alpha_{11}$	27°	30°	30°	
$\alpha_{12}$	74°	73°	76°	
$\alpha_{13}$	-	-	70°	
$\alpha_{14}$	-	-	6°	

Tab. 5

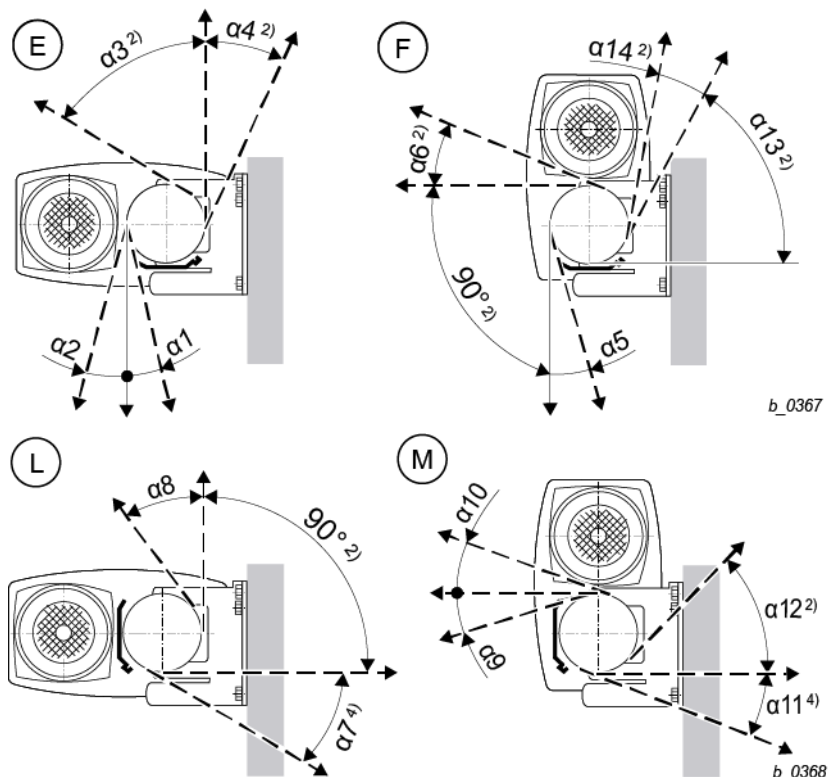
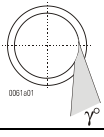

Fig. 12

- 2) By turning rope guide
  - 4) By turning rope guide and grease pan.
- Type YKE/SKE:** Version (H) not possible

## 4 Installation

Wire rope hoist type	 $\gamma$
	$\gamma$
YKA/SKA	39°
YKB/SKB	39°
YKC/SKC	39°
YKE/SKE	39°

Tab. 6

### 4.2.4 Fleet angle

1. Adjust the rope guide to the fleet angle.
2. Observe also the radial rope exit angle  $\gamma$ .

### 4.2.5 Angle of installation

#### ⚠ WARNING

**Rope damage hazard.** The wire rope must not touch the rope guide or structural elements.

- Always install the hoist horizontal.

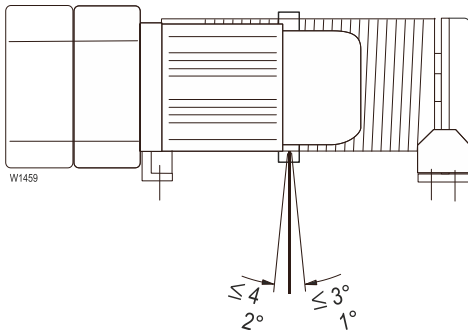

Fig. 13

1. Install hoists with rope drives with bottom hook blocks always horizontal to their longitudinal axis.
2. Do not exceed the fleet angle to the direction of the rope drum groove and the rope sheave of  $4^\circ/3^\circ$  for non-rotation-resistant wire ropes,  $2^\circ/1^\circ$  for rotation-resistant wire ropes. However even at these angles a reduction in service life is to be expected.
3. Equip rope sheaves with a suitable guard to prevent the rope jumping out of the groove, max. clearance of the guard  $<0.5 \times$  rope diameter. The rope must not slip off the sheave axle if the sheave breaks. The rope suspension must be designed to prevent kinking and other additional stresses. The rope suspension for non-rotation-resistant wire ropes must be designed so that it cannot rotate around its longitudinal axis. The rope spread angle of  $45^\circ$  in top hook position must not be exceeded.

## 4 Installation

### 4.3 Monorail trolleys

The trolleys are constructed according to the state of the art and supplied with mounted buffers.

#### 4.3.1 Monorail trolley (KE-S33 - 76)

with wire rope hoist types

YKA/SKA, YKB/SKB, YKC/SKC, YKD/SKD, YKE/SKE

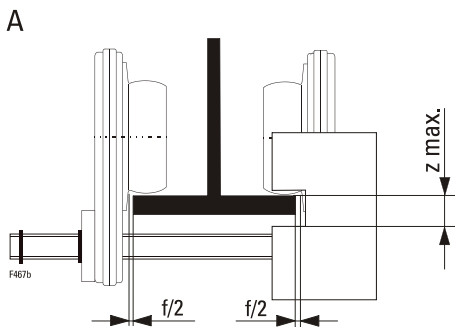
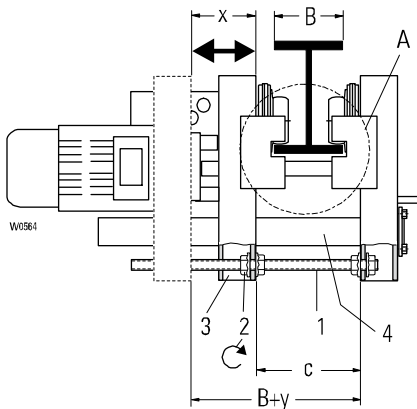

Fig. 14

#### NOTICE

**Material damage hazard.** If the flange width is altered (by customer), it may be necessary to alter the counterweight to prevent the trolley canting. Please have it checked by our after-sales service.

1. Check flange width “B” and clearance “c” against Tab. 7 and set trolley to beam width if necessary.

#### Installation if end of runway is freely accessible

1. Slide trolley onto end of runway and check play “f/2”.

#### Installation if end of runway is not accessible

1. Unscrew nuts (2) on threaded bolts (1) and slide trolley side cheek (3) outwards by approx. “x” in. or until dimension **B+y** is reached (Tab. 7).
2. Push hoist side of trolley onto lower flange of runway beam and secure against slipping.
3. Push trolley side cheek (3) towards the runway beam on support bolt (4).
4. Adjust dimension “c” with nuts (2), tighten nuts (2).
5. Check track gage “c” and play **f/2**.
6. Tighten nuts (2) with torque spanner to the specified tightening torque (see table below).

Hoist	Wheel Ø D [in]	Trolley	I	I	I II	I	c	f/2	x	y	z max	Tightening torque [lbr ft]
			INP	IPE	IPB	"						
YKA/SKA	3.1	KE-S33	B = 3.5...19.7 in				B+2.6 <sup>1)</sup>	0.059	2.8	5.4	1.04	155
YKB/SKB	3.9	KE-S44					B+2.6 <sup>1)</sup>	0.059	3.1	5.8	1.12	155
YKC/SKC	5.5	KE-S65	B = 4.7...19.7 in				B+2.6 <sup>1)</sup>	0.059	3.7	6.4	1.54	155
YKD/SKD	7.9	KE-S76	B = 4.9...19.7 in				B+3.6 <sup>1)</sup>	0.059	3.7	7.4	1.89	155
YKE/SKE												

Tab. 7

<sup>1)</sup> for INP beam: -0.079 in.



## 4 Installation

### 4.3.2 Drive shaft for travel drive (trolleys KE-S33 - KE-S65)

Ø D [in]	B [in]	Drive shaft		
		L [in]	Position	
3.1 3.9	3.5 - 5.7	15.4	X3	-
	5.7 - 7.7		-	X4
SF17 1.. SF17 2..	7.7 - 9.8	19.5	X3	-
	9.9 - 12		-	X4
	12.1 - 13.8	23.4	X3	-
	13.8 - 15.7		-	X4
	15.8 - 17.7	27.4	X3	-
	17.8 - 19.7		-	X4
5.5 SF17 2..	4.7 - 7.9	19.9	X3	-
	7.9 - 12.2		-	X4
	12.2 - 15.7	27.4	X3	-
	15.8 - 19.7		-	X4
7.9 SF17 2..	4.9 - 8.7	20.1	see next page	
	8.7 - 15.7	29.1		
	15.8 - 19.7	30.7		

Tab. 8

Ø D [in]	L3 ±0.079 [in]	L4 ±0.079 [in]
3.1	3.8	1.83
3.9		
5.5	4.91	1.83

Tab. 9

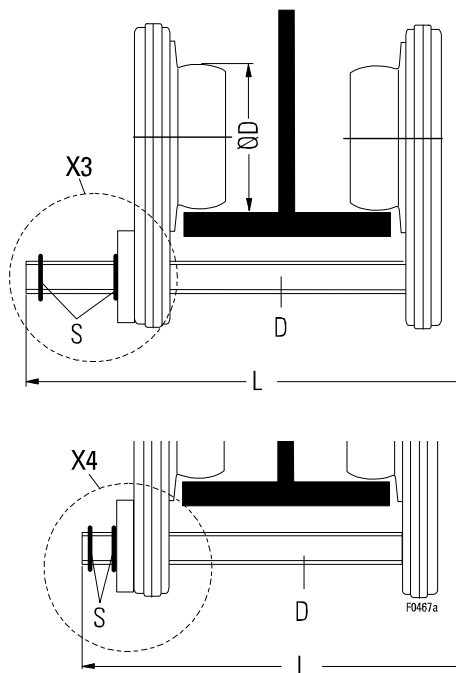

Fig. 15

1. Fit drive shaft in mounting position X3 or X4 depending on flange width (B) of runway beam and length (L) of drive shaft (D).
2. Fit circlips (S).

## 4.3.3 Drive shaft for trolley drive (trolley KE-S76)

The drive shaft is suitable for girder flange widths "B" from **4.9 in.** to **19.7 in.**

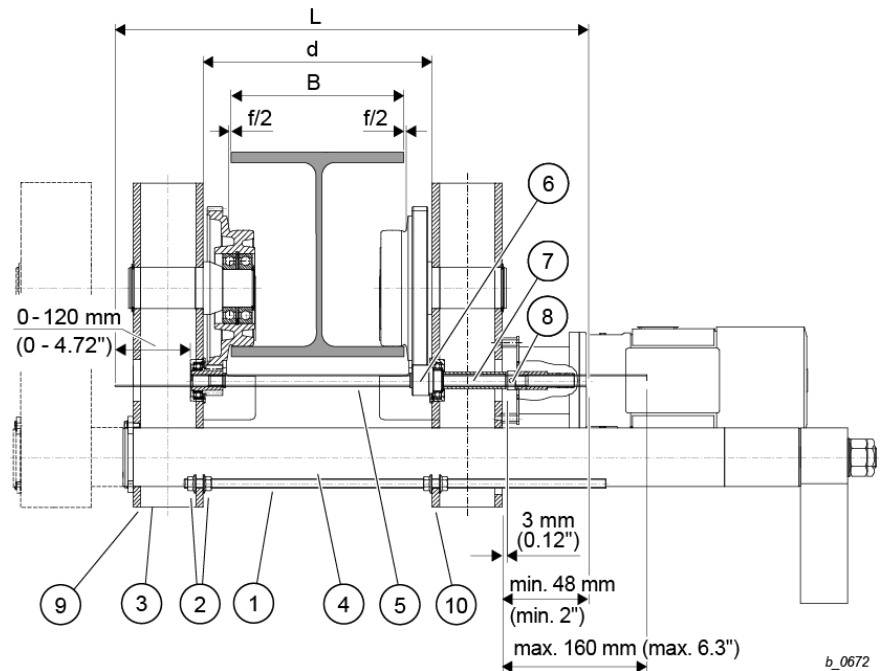

Fig. 16

Wire rope hoist type	Wheel Ø D [in]	Trolley	Travel drive	I	I	II	I	L [in]	d [in]	f/2	Tightening torque [lb <sub>r</sub> ft]
				INP	IPE	IPB	"				
YKD/SKD YKE/SKE	7.9	KE-S76	SF17 2..	B = 4.9 - 8.7 in				20	B+3.6 <sup>1)</sup>	0.059	155
				B = 8.7 - 15.7 in				29			
				B = 15.8 - 19.7 in				31			

<sup>1)</sup> for INP beam: -0.079 in.

1. Insert drive shaft (5) into the two drive pinions (6) from the counterweight side, then assemble spacer tube (7) and adjusting ring (8).
2. Adjust drive shaft (5) so that on the hoist side the shaft end projects by between **min. 0 in.** and **max. 4.72 in.** beyond the drive pinion (6) and on the counterweight side the shaft end projects by between **min. 1.9 in.** and **max. 6.3 in.** beyond the trolley side cheek (10).
3. Lock adjusting ring (8) with adjusting screw so that on spacer tube (7) lying against drive pinion (6) there is a play of **approx. 0.079 - 0.157 in.** to adjusting ring (8).
4. After fitting travel drive, check drive shaft (5) for ease of movement.

## 4.3.4 Monorail trolley (UE-S4) with YKB/SKB, YKC/SKC, 1PS wire rope hoists (single fall)

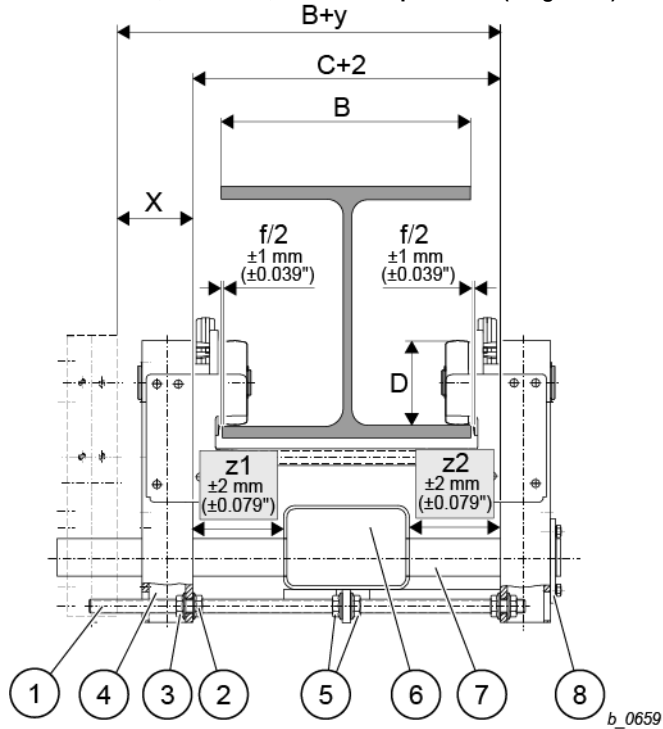

Fig. 17

Ø D [in]	Trolley	I				c	f/2	x	y	z max	Tightening torque [lbr ft]
		INP	IPE	IPB	"						
3.9	UE-S4	B = 3.5...19.7 in				B+2.6 <sup>1)</sup>	0.059	3	5.6	1.12	155

Tab. 10

<sup>1)</sup> for INP beam: -0.079 in.

1. Check flange width "B" and clearance  $c \pm 0.079$  in. against Tab. 10 and set trolley to beam width if necessary. Ensure that the connection piece (square tube) (6) is in the center (of dimension "c") between the trolley side cheeks ( $z1 = z2$ ).
2. After unscrewing nuts (3) together with nuts (2), adjust clearance  $c \pm 0.079$  in. and tighten nuts (3).
3. Tighten nuts with torque spanner to the specified tightening torques (see table above).
4. Clearance "c" results in a flange play of  $f/2 + 0.039$  in. on each side. If necessary, correct flange play by means of clearance "c".

### Installation if end of runway is freely accessible

1. Slide trolley onto end of runway and check play  $f/2$ .

### Installation if end of runway is not accessible

1. Loosen nuts (3) on threaded bolts (1) in the square tube of the trolley side cheeks (4) and unscrew by dimension "x".
2. Push trolley side cheeks (4) apart in parallel up to the unscrewed nuts (3) until dimension  $B+y$  or  $c+x$  is reached.
3. Slide trolley onto the bottom flange of the runway beam on the axle keep plate side (8) and secure against shifting.
4. Push trolley side cheeks (4) back to nuts (2), retighten nuts (3).
5. Check track gage  $c \pm 0.079$  in. and play of guide rollers  $f/2$ .
6. Tighten nuts with torque spanner to the specified tightening torques (see table above).

## 4 Installation

### Centering connection piece

1. Loosen nuts (5) and shift connection piece (6) on connecting bolt (7) so that dimensions "z1" and "z2" between trolley side cheeks (4) and connection piece (6) are equal on both sides.
2. Tighten nuts (5) with torque spanner to the specified tightening torques (see table above).

Ø D [in]	B [in]	Drive shaft		
		L [in]	Position	
3.1 3.9	3.5 - 5.7	15.4	X3	-
	5.7 - 7.7		-	X4
SF17 1.. SF17 2..	7.7 - 9.8	19.5	X3	-
	9.9 - 12		-	X4
	12.1 - 13.8	23.4	X3	-
	13.8 - 15.7		-	X4
	15.8 - 17.7		X3	-
	17.8 - 19.7		-	X4
5.5 SF17 2..	4.7 - 7.9	19.9	X3	-
	7.9 - 12.2		-	X4
	12.2 - 15.7	27.4	X3	-
	15.8 - 19.7		-	X4
7.9 SF17 2..	4.9 - 8.7	20.1	see next page	
	8.7 - 15.7	29.1		
	15.8 - 19.7	30.7		

### Connecting bolt and drive shaft

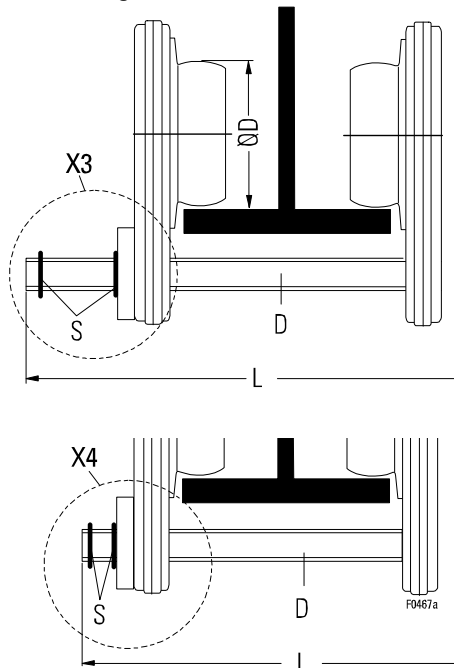

1. Use connecting bolt and drive shaft suitable for beam range "B".

**4.3.5 Monorail trolley (UE-S776)  
with YKE/SKE, 4PS wire rope hoist (four-fall)**

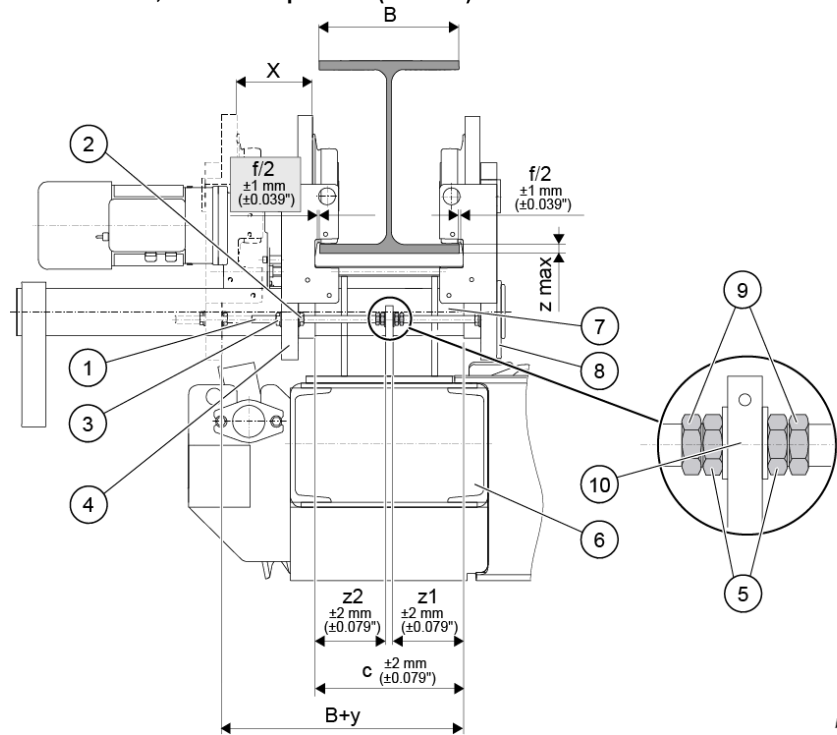

Fig. 18

b\_0587

Ø D [in]	Trolley	Beam Profile				c	f/2	x	y	z max	Tightening torque [lb <sub>f</sub> ft]
		INP	IPE	IPB	"						
7.9	UE-S776	B = 7.3...19.7 in				B+3.6	0.059	3.7	7.4	1.9	155

Tab. 11

1. Check flange width “B” and clearance  $c \pm 0.079$  in. against Tab. 11 and set trolley to beam width if necessary. Ensure that the connection piece (square tube) (6) is in the center (of dimension “c”) between the trolley side cheeks ( $z1 = z2$ ).
2. After unscrewing nuts (3) together with nuts (2), adjust clearance  $c \pm 0.079$  in. and tighten nuts (3).
3. Do not distort plate (10). Tighten nuts (5) lightly and then unscrew by a quarter turn. Lock nuts (9) against nuts (5) with a torque spanner (see table above).
4. Tighten nuts (3) with a torque spanner to the specified tightening torque (see table above).
5. Clearance “c” results in a flange play of  $f/2 + 0.039$  in. on each side. If necessary, correct flange play by means of clearance “c”.

**Installation if end of runway is freely accessible**

1. Slide trolley onto end of runway and check play  $f/2$ .

**Installation if end of runway is not accessible**

1. Loosen nuts (3) on threaded bolts (1) in the square tube of the trolley side cheeks (4) and unscrew by dimension “x”.
2. Push trolley side cheeks (4) apart in parallel up to the unscrewed nuts (3) until dimension  $B+y$  or  $c+x$  is reached, and lift trolley onto runway from below.
3. Slide trolley onto the bottom flange of the runway beam on the axle keep plate side (8) and secure against shifting.
4. Push trolley side cheeks (4) back to nuts (2), retighten nuts (3).
5. Check track gage  $c \pm 0.079$  in. and play of guide rollers  $f/2$ .
6. Tighten nuts (3) with a torque spanner to the specified tightening torque (see table above).

### Centering connection piece

1. Loosen nuts (5) and shift connection piece (6) on connecting bolt (7) so that dimensions "z1" and "z2" between trolley side cheeks (4) and connection piece (6) are equal on both sides.
2. Tighten nuts (5) with a torque spanner to the specified tightening torque (see table above).

### Connecting bolt and drive shaft

3. Use connecting bolt and drive shaft suitable for beam range "B" (for dimensions, see Fig. 19).

### Drive shaft for trolley drive (trolley UE-S776)

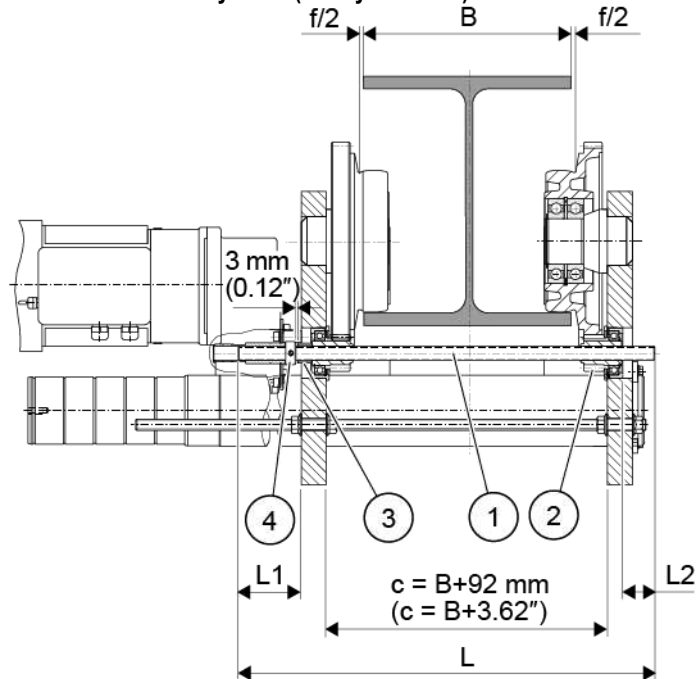

Fig. 19

B	L	L1	L2	f/2
[in]	[in]	[in]	[in]	[in]
7.3 - 8.7	20.1	3.3	5.1 - 3.7	0.059
8.7 - 14.2	24.4	3.3	6.8 - 1.3	
14.2 - 17.7	29.1	5.3	3.9 - 0.35	
17.8 - 19.7	29.1	3.3	2.3 - 0.35	

Tab. 12

The drive shaft is suitable for girder flange widths "B" from **7.3 in.** to **19.7 in.** (see Tab. 12 for length "L").

1. Insert drive shaft (1) into the two drive pinions (6) from the counterweight side, then assemble spacer tube (3) and adjusting ring (4).
2. Adjust drive shaft (1) to dimension "L1", dimension "L2" must lie between the values given in the table.
3. Lock adjusting ring (4) with adjusting screw.
4. After fitting travel drive, check drive shaft (1) for ease of movement. The axial play must be approx. **2 – 4 mm (0.08 – 1.57 in.)**

## 4.3.6 Articulated trolley (DKE-S4 / DKE-S6) with YKA/SKA, YKB/SKB, YKC/SKC wire rope hoists

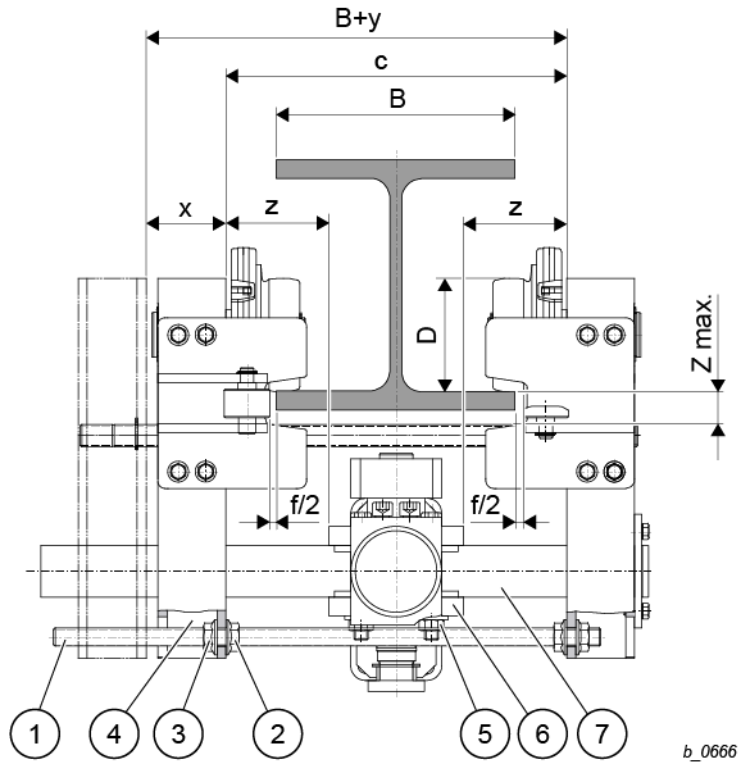

Fig. 20

Wire rope hoist type	Ø D [in]	Trolley	B	f/2	c	x	y	Z max	Tightening torque	
			[in]							Nut (3)
[lb ft]										
YKA/SKA, YKB/SKB	3.9	DKE-S4	3.5 - 11.8	0.059	B+3.1	2.6	5.8	1.1	159	63
YKC/SKC	5.5	DKE-S6	4.7 - 11.8	0.059	B+3.3	3	6.3	1.6	159	63

Tab. 13

1. Check flange width “B” and clearance “c” against Tab. 13 and set trolley to beam width if necessary.
2. Ensure that the connection piece (square tube) (6) is in the center (of dimension “c”) between the trolley side cheeks.
3. After unscrewing nuts (3) together with nuts (2), adjust clearance “c” and tighten nuts (3).
4. Tighten nuts (3) with a torque spanner to the specified tightening torque (see table above).
5. Clearance “c” results in a flange play of  $f/2 + 0.039$  in. on each side. If necessary, correct flange play by means of clearance “c”.

### Installation if end of runway is freely accessible

1. Slide trolley onto end of runway.

### Installation if end of runway is not accessible

1. Loosen nuts (3) on threaded bolts (1) in the square tube of the trolley side cheeks (4) and unscrew by dimension “**x**”.
2. Push trolley side cheeks (4) apart in parallel up to the unscrewed nuts (3) until dimension **B+y** or **c+x** is reached, and lift trolley onto runway from below.
3. Lift trolley onto runway from below.
4. Slide trolley onto the bottom flange of the runway beam on the hoist side and secure against shifting.
5. Push trolley side cheeks (4) back to nuts (2), retighten nuts (3).
6. Check track gage “**c**” and play of guide rollers **f/2**.
7. Tighten nuts (3) with a torque spanner to the specified tightening torque (see table above).

### Centering bogie

1. Loosen nuts (5) and shift bogie (6) on connecting bolt (7).
2. Dimension “**z**” between trolley side cheeks (4) and bogie (6) is equal on both sides.
3. Tighten nuts (5) with a torque spanner to the specified tightening torque (see table above).



## Drive shaft for travel drive (DKE-S4 / DKE-S6)

### Trolleys with one travel drive

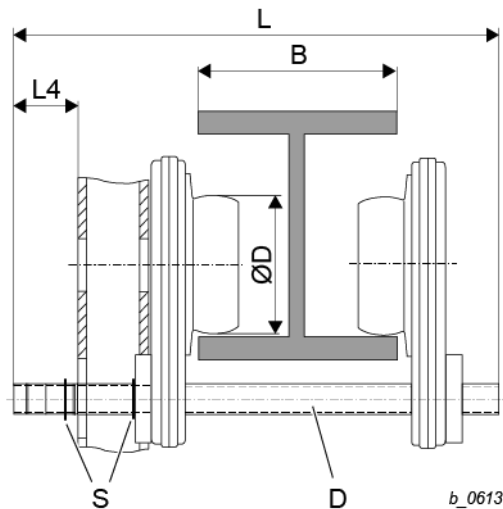

Fig. 21

Ø D	B	Drive shaft D	
		L	L4 ±0.079
[in]	[in]	[in]	[in]
3.9	3.5 - 5	15.4	1.83
	5.1 - 8.7	19.5	
5.5	4.7 - 11	19.5	
	11.1 - 11.8	28	

Tab. 14

The drive shaft "D" is suitable for beam widths "B" from 3.5 in. to 11.8 in.

1. Fit lock washers "S" acc. to dimension "L4".  
The mounting position of the drive shaft does not change over the corresponding beam range "B".

### Trolleys with two travel drives

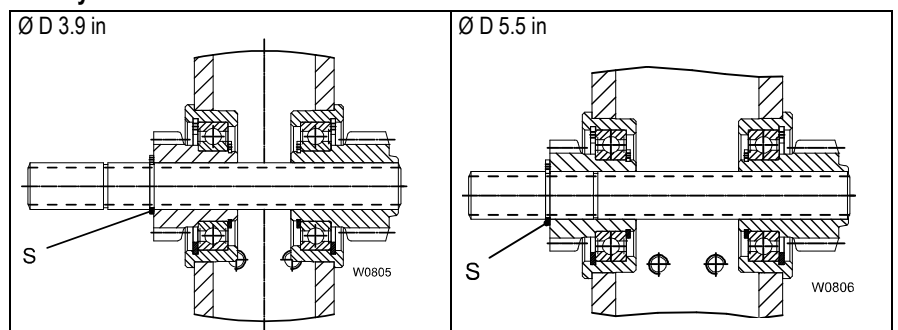

Fig. 22

The drive shaft is completely independent of the beam width.

1. Mount lock washers "S" acc. To Fig.21 and Fig. 22. Drawings above

## 4 Installation

### 4.4 End stops for monorail trolleys



#### ⚠ WARNING

**Falling parts hazard.** If there are no end stops, the trolley can travel over the end of the runway.

- Mount suitable end stops at the end of the runway before commissioning the hoist.

The monorail trolleys are supplied as standard with buffers. Suitable runway end stops, to be clamped onto the lower flange of the runway, can be supplied.



#### ⚠ WARNING

**Falling parts hazard.**

- With inclined flanges use supplied special screws.

	[mm]	[in]
A	112	4.41
B	134	5.28
C	56	2.2
D	≥ 15	≥ 0.59
E	70	2.76
F	63	2.48
G	33	1.3
H	see table below	see table below
J	7 - 35	0.28 - 1.38
K	25 - 40	0.98 - 1.57
L	70	2.76
M	40	1.57
N	94	3.7
P	134	5.28
Q	≥ 15	≥ 0.59
R	56	2.2
S	105	4.13
T	190	7.48

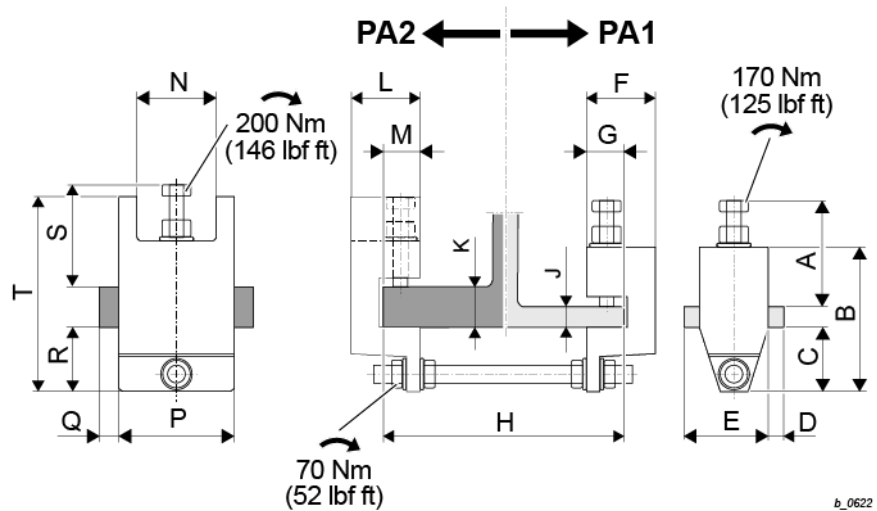

Fig. 23

b\_0622

	Type <sup>1)</sup>	b max. [in]	Weight [lb]	Trolley		E max. [lbf ft]	Max. buffer force [lbf]	Order No.
				Type	max. [ton]			
	PA1/300	≤11.8	13	≤YKD/SKD, 4PS (≤KE-S76)	17.6	207	9663	01 740 57 27 0
	PA1/500	11.8-19.7	14					01 740 58 27 0
	PA1/1000	19.7-39.4	14					01 740 64 27 0
	PA2/500	≤19.7	31	≤YKE/SKE, 4PS (≤UE-S77)	35.3	251	8989	01 740 59 27 0
	PA2/1000	>19.7-39.4	32					01 740 65 27 0
	PA1/300	≤11.8	13	≤YKD/SKE, 4PS (≤KE-S76)	17.6	207	9663	01 740 57 27 0 01 740 00 92 0 <sup>2)</sup>

Tab. 15

- Limit switches necessary for travel speeds  
> 105 fpm (PA1)  
> 82 fpm (PA2)
- Special screw (must also be ordered)

## 4 Installation

### 4.5 Double rail trolley (OE-S)

The double rail trolleys are supplied with mounted buffers.

#### NOTICE

The trolley must run smoothly over the whole runway without jamming or increased friction at the wheel flanges. Increased friction at the flanges due to poor beam quality or incorrect trolley adjustment may lead to increased wear.

➤ Ensure that the trolley runs smoothly without increased friction at the wheel flanges.

1. The runway must meet the requirements of ISO 12488-1.
2. Make sure that the rail joints are even on both running and guide surfaces. Grind down if necessary.

#### Check track gage

Ø D [in]	S [in]
3.9	0.1 - 0.2
4.9	0.1 - 0.2
6.3	0.14 - 0.24
7.9	0.18 - 0.28

Tab. 15

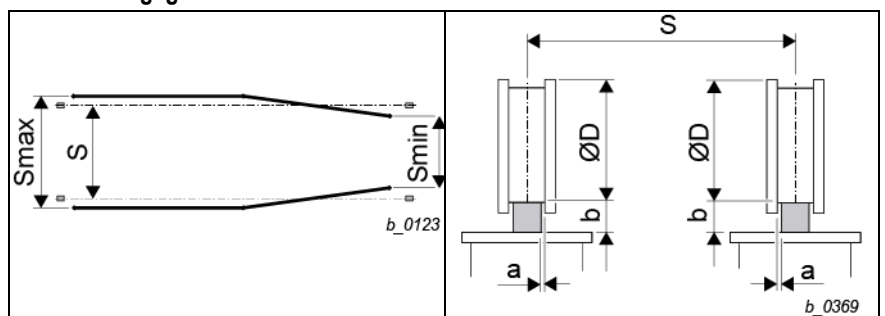

Fig. 24

1. Check track gage "S" on trolley and rail ( $S_{max} - S_{min} = 0.197$  in.)
2. Check lateral play "S" between rail and flange.
3. "S" as per Tab. 15, if trolley is positioned symmetrically on runway.  
If asymmetrically,  $S_{left} + S_{right} = 2 \times S$ .

#### Transport anchor screws

(only on trolleys with wheel diameter  $D = 4.9$  in.)

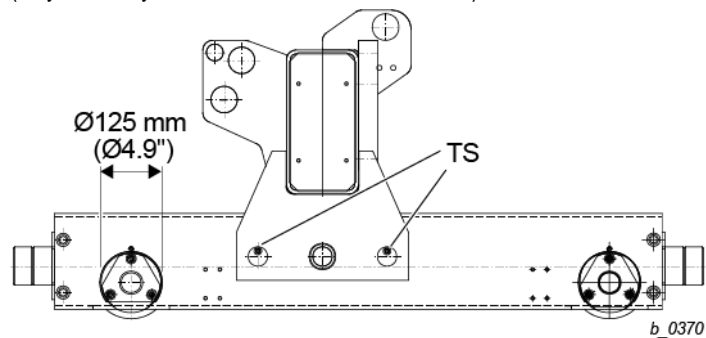

Fig. 25

1. Remove transport anchor screws "TS".

#### Bolt buffers and stops

1. Bolt rubber buffers to trolley or runway end stop.
2. Fit suitable stops (dimensions see next section).

## 4 Installation

### 4.6 End stops for double rail trolleys

#### ⚠ WARNING



**Falling parts hazard.** If there are no end stops, the trolley can travel over the end of the runway.

➤ Mount suitable end stops at the end of the runway before commissioning the hoist.

#### 4.6.1 Wheel diameter $D = 3.9$ in.

Pos	[mm]	[in]
A	90	3.54
B	200	7.87
C	88	3.46
D	Ø100	3.94

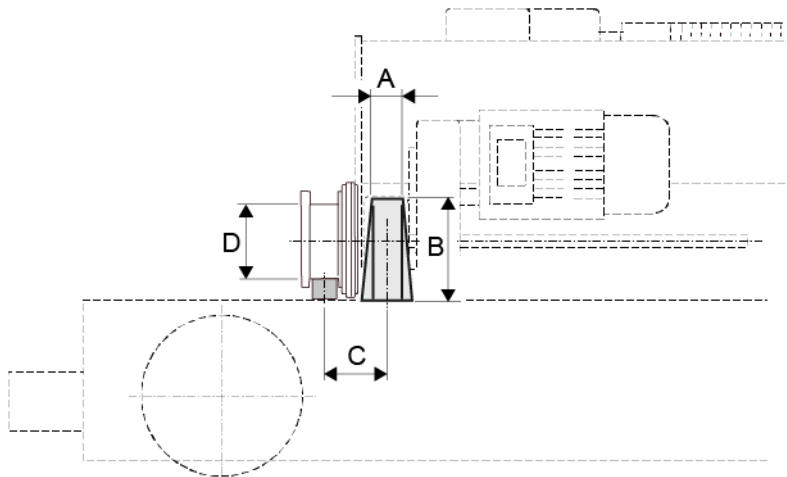

Fig. 26

b\_0371

#### 4.6.2 Wheel diameter $D = 4.9 - 7.9$ in.

Pos	[mm]	[in]
D	Ø 125	Ø 3.94
	Ø 160	Ø 6.3
	Ø 200	Ø 7.87
H	97	3.82
	100	3.94
	100	3.94

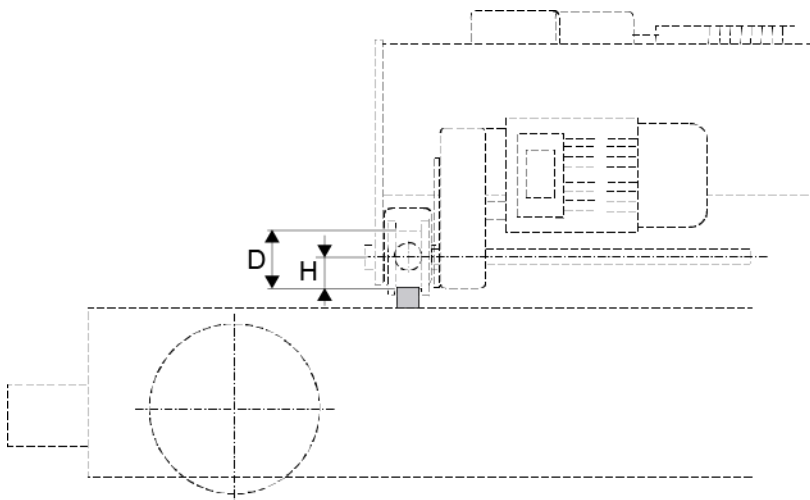

Fig. 27

b\_0372

Tab. 16

## 4 Installation

### 4.7 Anti-jump catch

#### 4.7.1 Description of system

The anti-jump catch acts as an anti-derail device, preventing the trolley jumping off the rail and falling.

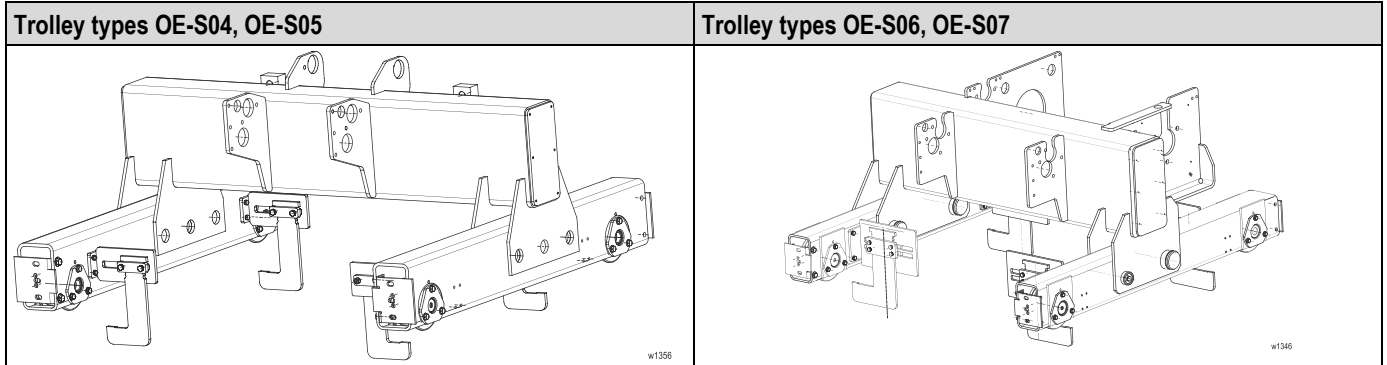

Fig. 28

Fig. 29

#### 4.7.2 Procedure

**⚠ WARNING**



**Falling parts hazard.**

- Cordon off and secure danger area during installation and dismantling work.

The anti-jump catch is supplied pre-mounted on the trolley and must be adapted to the actual runway situation.

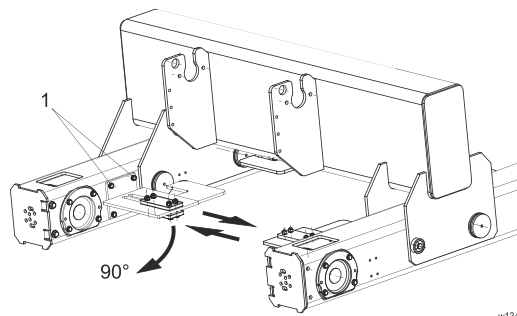

Fig. 30

1. Unscrew fixing screws (1) of anti-jump catch.
  2. Swivel the whole unit by 90° and re-screw.
- Tightening torque **M8 = 8.4 lbf ft**, **M10 = 37.6 lbf ft**.

#### Trolley type OE-S07 4PD

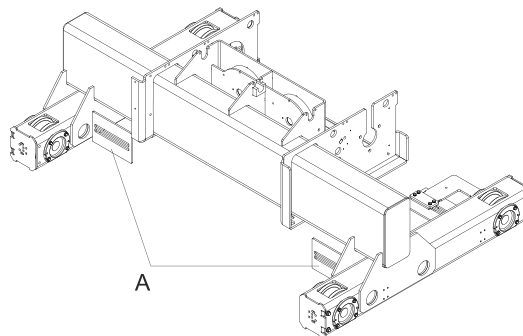

Fig. 31

There are two retaining plates "A" welded in place.

1. Swivel two units of the anti-jump catch by 90°.

## Vertical adjustment

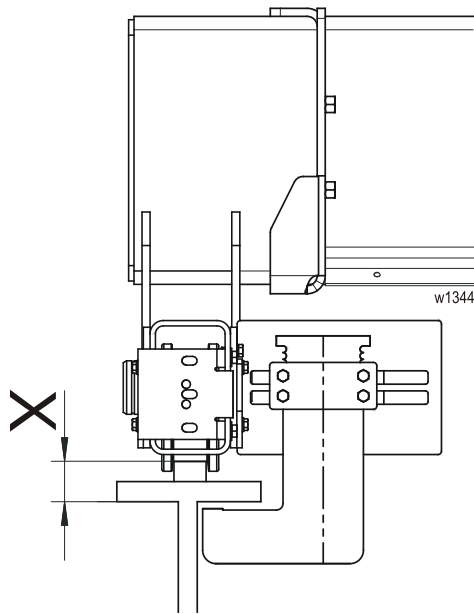

Fig. 32

1. Measure dimension "X".
2. Select positions of hook and eccentric from the table.

### Trolley type OE-S04

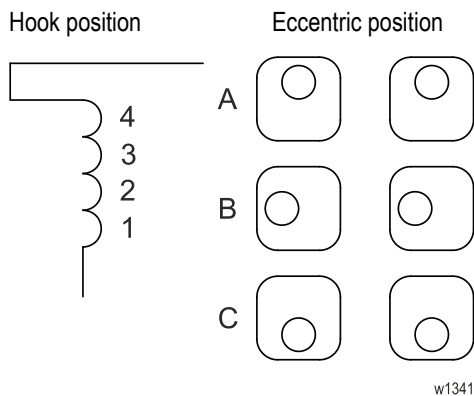

Fig. 33

### Trolley type OE-S04

X [in]	Hook position	Eccentric
1.65 - 1.77	1	B
1.79 - 1.89		C
1.91 - 2.05	2	A
2.07 - 2.17		B
2.19 - 2.28		C
2.3 - 2.44	3	A
2.46 - 2.56		B
2.58 - 2.68		C
2.7 - 2.83	4	A
2.85 - 2.95		B

### Trolley type OE-S05

X [in]	Hook position	Eccentric
1.57 - 1.69	1	B
1.71 - 1.81		C
1.83 - 1.95	2	A
1.97 - 2.09		B
2.11 - 2.2		C
2.22 - 2.34	3	A
2.36 - 2.48		B
2.5 - 2.6		C
2.62 - 2.74	4	A
2.76 - 2.87		B
2.89 - 2.99		C
3.01 - 3.13	5	A
3.15 - 3.27		B

### Trolley type OE-S05

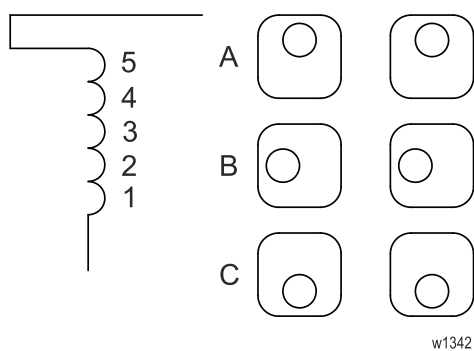

Fig. 34

## 4 Installation

### Trolley types OE-S06 - OE-S07

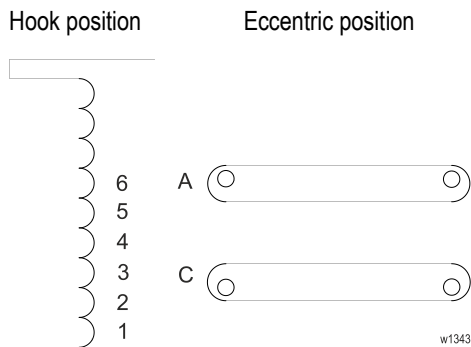

Fig. 35

X [in]	Hook position	Eccentric
1.5 - 1.59	1	A
1.61 - 1.79		C
1.81 - 1.99	2	A
2.01 - 2.19		C
2.2 - 2.38	3	A
2.4 - 2.58		C
2.6 - 2.78	4	A
2.8 - 2.97		C
2.99 - 3.17	5	A
3.19 - 3.37		C
3.39 - 3.56	6	A
3.58 - 3.76		C

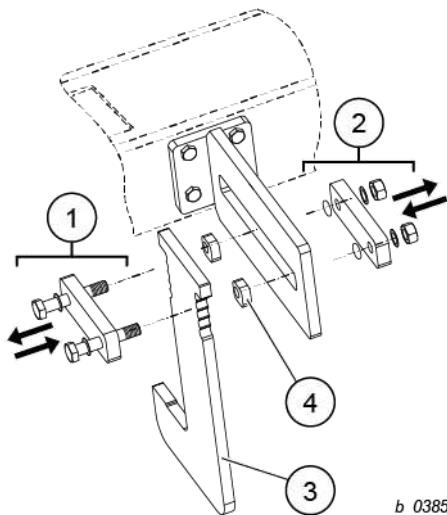

Fig. 36

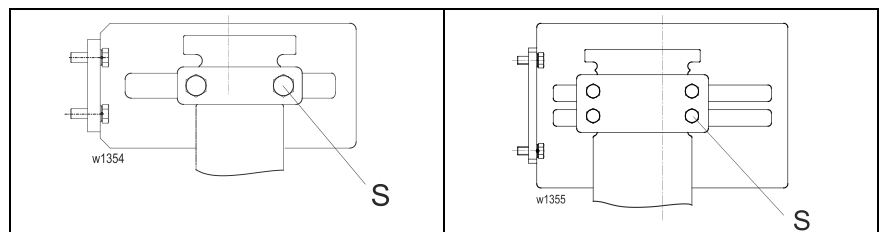

Fig. 37

Fig. 38

1. Unscrew fixing elements (1) and (2).
2. **OE-S07 4PD:** The pieces of two units are supplied loose (please unscrew as required).
3. Remove hook (3)
4. **OE-S04:** Rotate hook by 180°.
5. Insert adjusting screws "S" in the hook position determined from the table.
6. Position eccentric plates (4) in slot as specified by the table.
7. Tighten fixing elements (1) and (2) finger-tight.

#### Horizontal adjustment:

Pos	OE-S04 -OE-S05	OE-S06 - OE-S07
	[in]	[in]
Z	≥ 0.39	≥ 0.59
Y	≥ 1.18	≥ 1.18

1. Adjust final hook position according to Fig. and table.
2. Tighten fixing elements (1) and (2) with tightening torque **M10 = 38 lbf ft.**

#### NOTICE

**Malfunction hazard.** In the event of a fault, e.g. trolley running into the runway end stops unchecked, broken rope, all elements of the anti-jump catch must be checked immediately for damage/faults and completely replaced if necessary. The functional reliability of the system must be ensured.

Fig. 39

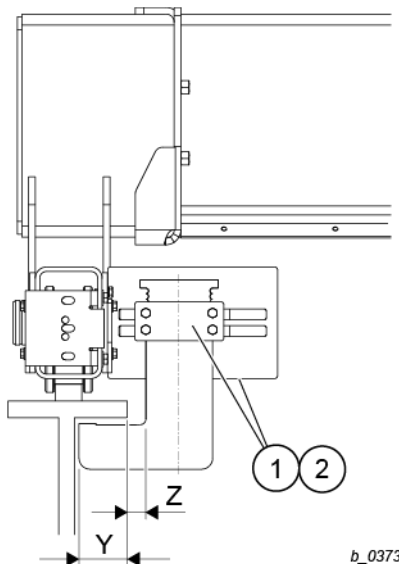

b\_0373

## 4 Installation

### 4.8 Travel limit switches

#### 4.8.1 Monorail trolley

The travel limit switches (optional) are mounted on the trolley.

#### 4.8.2 Double rail trolley

The travel limit switch assembly is supplied ready-wired but not mounted and must be secured to the towing arm for the power supply.

#### ⚠ WARNING



**Falling parts hazard.** If limit switches are defective, wrongly installed or wrongly set, the trolley will run into the end stops without being braked.

➤ Check the correct functioning and settings of the limit switches before commissioning

The switching contacts are designed for control current.

Switching functions:

- Limit switching in both directions of travel (1 two-way switch, 2 ramps).
- Pre-switching and limit switching in both directions of travel (1 two-way switch, 4 ramps).

The speed is switched over from “fast” to “slow” before the end of the runway is reached, and is cut off at the end of the runway.



Fig. 40

X = stop, left  
Y = stop, right  
Z = fast / slow

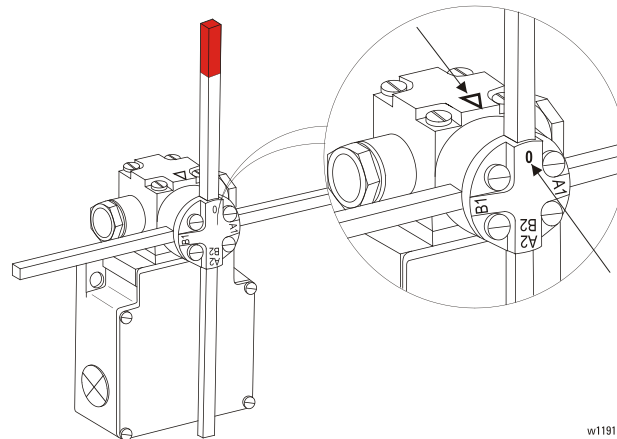

Fig. 41



There is no mechanical stop after the switch has been activated twice in the same direction.

➤ When mounting, ensure that the cross of the switch is in neutral position.  
Red mark = 0

Neutral position: “0” on the rotating head coincides with the arrow marking on the switch housing.



### 4.9 Electrical equipment



#### **⚠ DANGER**

##### **Electric shock hazard**

- Make sure an electrical qualified person performs the work.
  - Observe the relevant safety and accident prevention regulations.
- 

The electrical equipment of the hoist was designed, manufactured and tested in accordance with standard EN 60204-32. It comprises all electrical equipment of the hoist: Electrical equipment was installed per NFPA 70 or other National, State, and Local regulations.

- Energy supply (main isolator, conductor lines...)
- Energy distribution (transformers, crane disconnect switch, special circuits...)
- Operator interface and control devices mounted on the hoist (control pendant, radio transmitter, devices for emergency stop, limit switches...)
- Hoist control (electronic control devices, safety devices, radio receiver...)
- Drive, motor controls (power contactors, inverters...)
- Main drives (motors, brakes...)
- Auxiliary drives, sensors, load suspension equipment, actuators...)

#### **4.9.1 Supply cables**

Electrical service can be either power by cable or guarded system having sliding show contacts or wheel type collectors.

1. See section 11.3 for minimum cross-section and max. length of supply cable.
2. Select cables, leads and conductor lines to match the existing operating conditions (e.g. voltage, current, protection against electric shock, amassment of cables and leads) and for external influences (e.g. ambient temperature, presence of water or corrosive materials, mechanical stress).

#### **4.9.2 Terminals**

1. Check that all terminals are firm.

### 4.9.3 Protection of equipment

Protective devices include:

- Devices for overcurrent protection (fuses, circuit breakers)
- Motor protection devices
- Overload safety devices
- Temperature monitors
- Limit switches

The protective devices in the electrical equipment installed in the scope of supply must in no case be removed, replaced by different devices or bridged.

If a protective device has reacted, the hoist must not be put back in service until the cause has been determined and eliminated with the assistance of a qualified person.

### Overcurrent protection devices

Every hoist must have devices for disconnecting and switching the power supply. This function is performed by the following devices:

### 4.9.4 Emergency stop

It must be possible to disconnect the system electrically from the operating position. This function can be provided by:

- Emergency stop button in the control pendant in conjunction with the crane switch contactor
- Main isolator.

### 4.9.5 Runway conductor disconnecting means

- must disconnect the wire rope hoist on all poles,
- must be lockable in OFF position,
- must be installed in an easily accessible place in the system,
- must be marked as such to avoid mistakes.

### 4.9.6 Disconnect switch

Required for one or more hoists,

- must be lockable in OFF position.

### 4.9.7 Connection fuses

- Overcurrent protection devices.
- The fuse values must be observed so that the crane switch contacts do not weld if there is a short circuit and overload protection of lead is ensured.

### 4.9.8 Electromagnetic compatibility

Electromagnetic compatibility (EMC) mainly concerns the emission of electromagnetic interference and the immunity of electronic components and systems to this interference. If the following interference suppression measures are correctly installed and applied, the equipment will not cause any electromagnetic interference above the level permissible for the intended operating environment and have sufficient resistance to electromagnetic interference to function without error.

Detailed information on EMC-compliant installation is given in a separate instruction manual. The system builder is responsible for the EMC of the system as a whole.

In general, the product is designed for the operating environment "industrial environment", or "2nd environment" in the case of use of frequency-controlled drives.

The electronic control devices of the overload protection and any frequency inverters installed are interference-suppressed. You will find further information in the relevant operating instructions of the devices.

The contacts of power contactors and rectifiers for motor brakes may generate interference exceeding the permissible values depending on output, cable length and other system parameters.

Ready-to-connect electric wire rope hoists with declaration of conformity complying with machinery and EMC directives are interference-suppressed for the above operating environment.

No particular protective measures have been taken on electric wire rope hoists with control by customer or crane builder's control. Appropriate precautions must be taken by the customer in order to comply with EMC standards with regard to interference values.

In order to achieve an optimum result with minimum outlay, we recommend using our radio interference suppression module FEM1 for the YK/SK wire rope hoist.

- Order no. 578 525 0 ≤ 415 V
- Order no. 578 526 0 ≤ 800 V

Clip the module onto the top-hat rail and connect it to the mains supply cable.

## 4.9.9 Overload safety device

The wire rope hoist is supplied with an overload protection.

### Description of system

The overload safety device is a device which automatically prevents the hoist moving loads exceeding its safe working load during normal operation, taking into account the dynamic effects. This is achieved by measuring the force transmitted with the aid of a sensor and cutting the energy supply to the hoist drive and brake (stopping the hoist motion) (indirect-acting overload protection). In hoist controls the overload protection (safety-related function) is provided by various components (SRP/CS). The point of departure is where the safety-related signals are generated and the endpoint is the output of the power control elements. The electronic control device (SLE/SMC) acts as a safety device.

The protective devices of the electrical equipment installed in the scope of supply must in no case be removed, replaced by different devices or bridged.

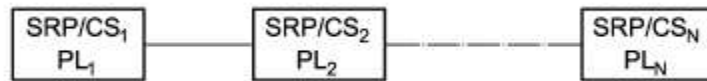

Fig. 42

Load sensor

Safety device

Contactor or inverter control

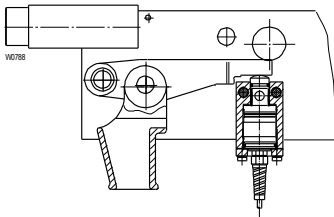

Fig. 43

### Load measurement at rope anchorage

(reevings: 2PS, 4PS, 2PD, 4PD)

#### with electronic pressure sensor

The overload safety device is set to maximum working load +10%.

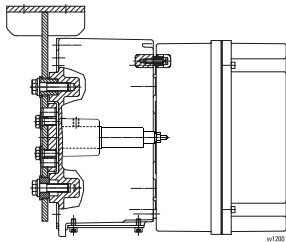

Fig. 44

### Load measurement at gear

(reevings: 1PS, 1PD)

#### with electronic shear force sensor

The overload safety device is set to maximum working load +10% overload.

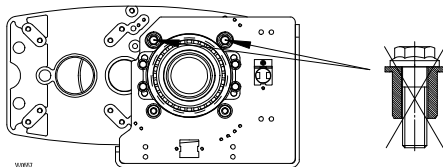

Fig. 45

### NOTICE

On YKB/SKB and YKC/SKC wire rope hoists with 1PS and 1PD reevings, remove the transport anchor screws marked in red after installation and before commissioning.

### Overload safety device by others



When an overload safety device and thus the placement of the load sensors to measure the rope forces are designed by others, all requirements relating to rope reeving, fleet angle and angle of installation of the hoist must be observed, see chap. 4.2

The overload safety device must be set during commissioning, see supplementary operating instructions.

The declaration of conformity/declaration of incorporation only apply to the manufacturer's scope of delivery.

The overload safety device cannot be set by the manufacturer if it is provided by others.

### 4.9.10 Connecting to mains

#### WARNING

**Safety hazard.** If this procedure is not observed, serious accidents or damage to the hoist may occur!

---

1. Compare existing mains voltage and frequency with the information on the rating plate.
2. Route cables into the hoist connection box through the cable glands.
3. Connect according to the circuit diagrams supplied.
4. Measure control voltage. If the measured value exceeds the rated control voltage by more than 10%, a different tapping point must be selected on the primary side of the control transformer.
5. Do not connect any live lead to the temperature sensors! Damaged temperature sensors cannot protect the motor.

#### WARNING

On three phase hoists, it is possible to have "Reverse Phasing" causing the block to lower when the "UP" button is depressed. When this condition exists, the hoist operation will be dangerous.

---

6. Check that the direction of rotation of the rope drum corresponds to the symbols on the control pendant: Activate "**slow up**" button on control pendant. Never activate "**down**" button first! If the hook moves upwards or does not move because the hoist limit switch has disconnected in top hook position, the phase connection is correct.
7. Crosscheck by activating "**slow down**" button on control pendant.
8. If the movement of the hook does not correspond to the symbols on the control pendant, interchange two phase conductors of the supply cable.

### 4.9.11 Control and control functions

Each hoist control is equipped with an electronic control device. This electronic control device functions as a central safety device for the overload safety device and as motor control and monitoring unit. The device functions are adapted to the different hoist and drive types and the particular function modules selected (load limits, pole-changing or frequency-controlled motors, etc.) by parameterising the device.

Two variants are used for this electronic control pendant:

#### Variant 1

- SLE load monitor
- Standard control
- Parameterized with HEX and DIP switches

#### Variant 2

- SMC multi-controller
- Extended functions - optional device
- Parameterized with config-tool and RS232 data interface or a USB interface

The following safety functions are integrated into the electronic control devices:

- Overload safety device
- Crane test possible with the aid of test button
- Protection against unexpected start-up
- Control of hoist motors with motor management

In addition, the devices perform the following non-safety-relevant control functions:

- Recording operating hours
- Temperature control for hoist and travel motors
- Display of system status

The general description of the control merely provides an outline. Detailed information on technical data, functions, integrating the control supplied into superordinate crane controls and troubleshooting are described in separate operating instructions for the electronic control devices and shown in the circuit diagrams. The same applies for frequency inverter controls.

#### Controls by others

- If the unit is being supplied less controls. CMCO cannot guarantee hoist / motor performance utilizing controls not recommended or provided by CMCO.
- If the controls are supplied by others, connect the temperature sensors of the hoist and travel motors, the hoist brake, the overload safety device and the emergency hoist limit switch according to the connection diagrams.
- Do not connect any live lead to the temperature sensors! Damaged temperature sensors cannot protect the motor.
- When integrating the supplied control sections into an overall control, the product standards for hoists and technical specifications as regards functionality, signal sequence and timing of this control must be observed. The circuit diagrams and block circuit diagrams supplied as hoist documentation must be followed and implemented by the customer when constructing the control. The system builder is responsible for the system as a whole.



The declaration of conformity / declaration of incorporation are valid only for the scope supplied by the manufacturer.

### 4.9.12 Electric motors and related equipment

The hoist motors meet the standards of EN 60034-1 and are specially dimensioned and designed for hoist operating conditions.

#### Hoist motor

- 12/2-pole motor with separately controlled D.C. brake for contactor control
- The brake is designed as an operating brake  
or
- 4-pole motor with separately controlled D.C. brake for frequency control
- The brake is designed as a holding brake and discharges the function of emergency stop
- Encoder with 600 pulses/rotation mounted on motor as standard (see encoder type plate and electrical switch diagrams).

#### Travel motor

- 8/2- pole motor with separately controlled D.C. brake for contactor control
- Integrated centrifugal mass for smooth acceleration and braking  
or
- 4- pole motor with separately controlled D.C. brake for frequency control

The motors are equipped with closable condensation holes 1). All motors have ptc sensors integrated into the winding as thermal overload protection.

#### Specification:

Thermal class:	F / H	Utilization / insulation system
Construction:	IM B5	flange mounting on drive side
Cooling:	IC 411	surface cooling with integrated fan

#### Standard operating conditions

- -4°F ... +104°F
- Humidity up to 80%
- Air pressure up to 3280 ft above sea level

#### Options

- IP 66 1)
- Forced ventilation
- Space heating 1)
- Manual release for brake

1)

Motors whose winding is subject to condensation due to climatic conditions, e.g. motors standing still in damp environments or motors exposed to high temperature fluctuations can be equipped with space heaters. They must also always be used in combination with type of protection IP 66 and high humidity.

### 4.10 YK/SK hoists with frequency inverter (VFD)

For information on the frequency inverter, see the separate instructions.

### 4.11 Reeving rope

The wire rope is wound onto the drum in the factory. If not, see page 80, section **7.14.4 “Replacing wire rope”**.

The wire rope hoist must be switched on in order to reeve the rope. All work must therefore be carried out with extreme care: for your safety and for smooth functioning of the wire rope hoist!

If the bottom hook block is not fitted, proceed as follows:

1. Gripper pliers hold the rope securely with a gripper pliers.
2. Lay out the end of the rope not wound on the drum, or let it hang freely.
3. Check that the wire rope lies snugly on the rope drum, tighten if necessary.

If the fit is loose:

Dismount the rope guide, see page 79, section **7.14.3 “Removing rope guide”**

Tighten up the wire rope on the rope drum and tension.

Mount the rope guide, see page 81, section **7.14.5 “Fitting rope guide”**

#### NOTICE

**Material damage hazard.** Slack rope can destroy the rope guide and the wire rope. Avoid slack rope on the drum.

1. Color code the beginning of the rope on one side.

Reeve the end of the rope into the rope sheave(s) of the bottom hook block and return pulley(s) (see next page for details).

#### NOTICE

**Material damage hazard to wire rope.** Do not twist the rope, the color coding facilitates checking.

2. Fasten the end of the rope in the rope anchorage
3. Perform several runs over the full height of lift without load.
4. Repeat with increasing loads.
5. Make any twisting in the rope which may occur visible by sticking on a paper tag. Severe twisting is shown by the bottom hook block's turning, especially when not under load.

#### NOTICE

**Material damage hazard.** Twisted ropes compromise safety and damage the rope. If any twisting occurs, remove the wire rope and untwist by letting it hang freely or laying it out. Twisting in the wire rope prejudices safety and service life. Any twisting must therefore be removed before subjecting the hoist to any further load. The rope could otherwise be permanently distorted and might have to be replaced!

#### Reeving rope (YKA/SKA – YKE/SKE)

#### NOTICE

Reeve the rope as shown in the schematic drawings and attach the end of the rope at the rope anchorage. The bottom hook block must hang horizontally (/2-1)

The hook may rotate after a short time in operation due to residual stress in the rope



Fig. 46



# 4 Installation

	YKA/SKA - YKC/SKC	YKE/SKE
1PS	1	1
2PS	2	4
4PS	3	5
1PD	6	6
2PD	7	8
4PD	-	9

Tab. 17

	YKA/SKA - YKC/SKC	YKE/SKE
2PS	4	4
4PS	5	5
2PD	8	8

Tab. 18

	YKA/SKA - YKC/SKC	YKE/SKE
2PS	4	4
4PS	5	5
2PD	8	8
4PD	-	9

Tab. 19

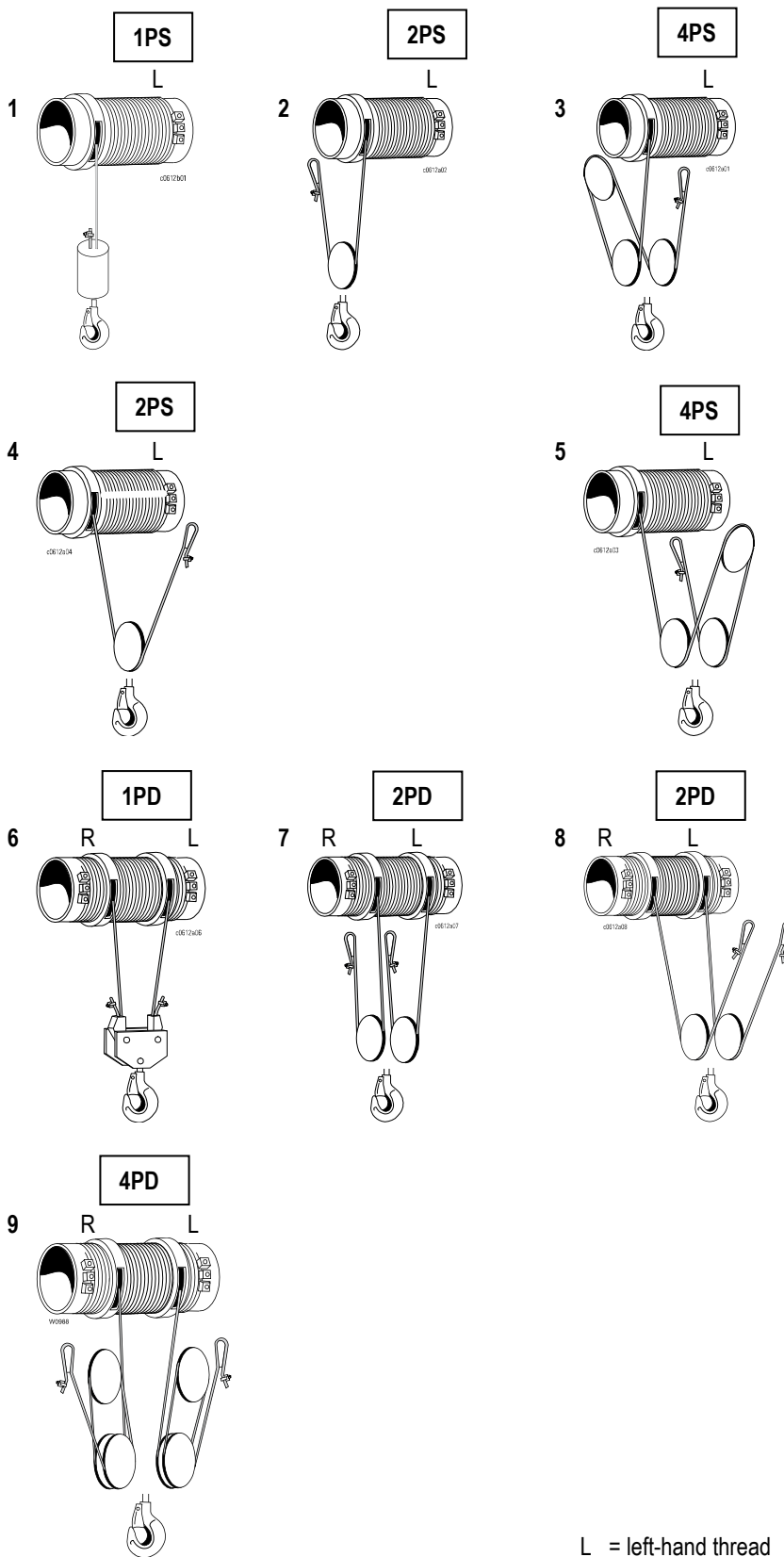

Fig. 47

L = left-hand thread  
R = right-hand thread

## 4 Installation

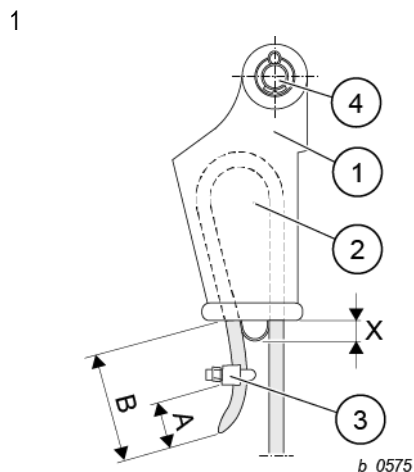

Fig. 48

### Rope anchorage (YKA/SKA – YKE/SKE)

	YKA/SKA – YKB/SKB		YKC/SKC – YKE/SKE	
	[mm]	[in]	[mm]	[in]
Xmax	6	0.24	15	0.59
A	50	1.97	50	1.97
B	100	3.94	100	3.94

1. Observe information plate at rope anchorage.
2. Insert end of rope into rope anchorage according to reeving
3. Place rope around rope wedge (2) and pull it into the tapered rope recess (1) until the loose end of the rope projects by approx. **3.9 in.**
4. Secure loose end of rope with rope clamp (3) approx. **2 in.** from the end of the rope (see table below left for tightening torque).
5. Max. projection of rope wedge:  
**YKA/SKA – YKB/SKB: Xmax = 0.24 in.**  
**YKC/SKC – YKE/SKE: Xmax = 0.59 in.**
6. Replace split pin (4) after dismantling it. Bend ends of split pin up.

### ⚠ WARNING



**Falling parts hazard.** Ropes which are not secured as specified may lead to the rope slipping and the load falling.

- Always insert the rope correctly into the rope anchorage and secure.
- Replace split pin every time it is dismantled.

Rope Ø [in]	Metric	Tightening torque [lbf ft]
0.2-0.26	M6	4
0.28-0.31	M8	7
0.33-0.39	M8	15
0.47-0.49	M12	30
0.55-0.63	M14	70
0.79	M16	96

Tab. 20

Length L				
	YKA/SKA	YKB/SKB	YKC/SKC	
2PS	L2	12	12	12
	L3	12	12	12
	L4	-	-	-
4PS	L2	21	14	22
	L3	21	14	22
	L4	-	-	22
2PD	L2	17	18	17
	L3	17	18	17
	L4	-	-	17

Tab. 21

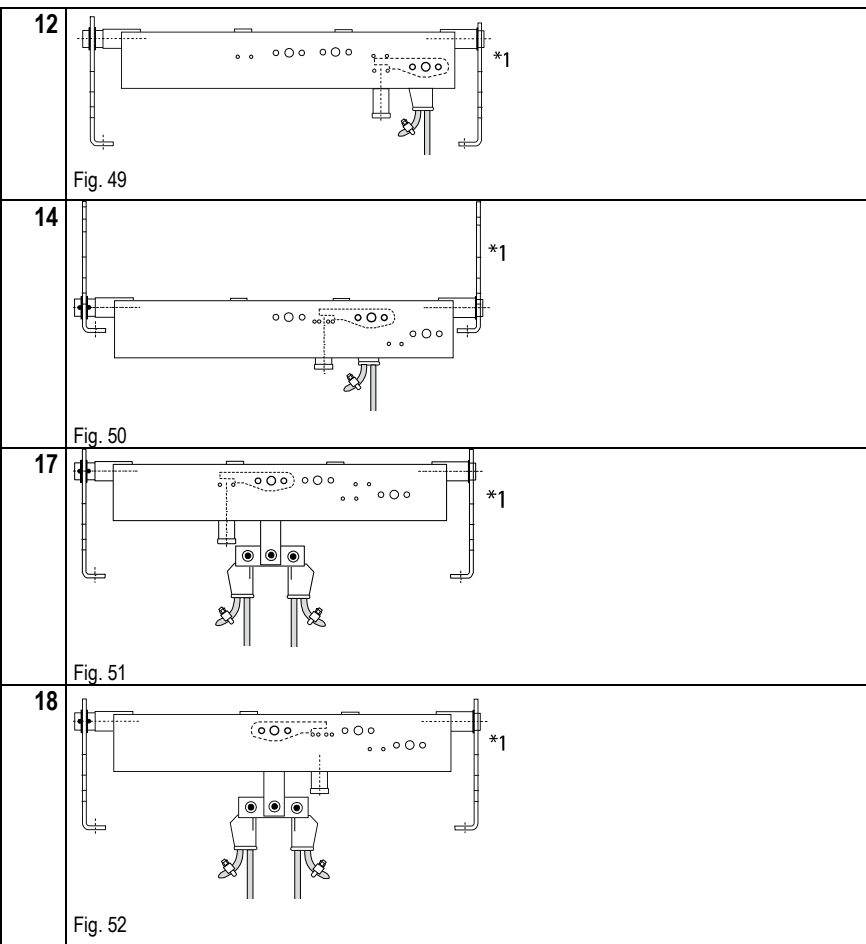

\*1 Gear side

# 4 Installation

	Length L	YKA/ SKA	YKB/ SKB	YKC/ SKC
2PS	L2	12	12	12
	L3	12	12	12
	L4	-	-	-
4PS	L2	21	14	22
	L3	21	14	22
	L4	-	-	22
2PD	L2	17	18	17
	L3	17	18	17
	L4	-	-	17

Tab. 22

	Length L	YKA/ SKA	YKB/ SKB	YKC/ SKC
2PS		24	24	24
4PS		23	23	23
2PD	L2	25	25	25
	L3	26	26	26
	L4	-	-	26

Tab. 23

	Length L	YKA/ SKA	YKB/ SKB	YKC/ SKC
2PS		28	28	28
4PS		27	27	27
2PD	L2	29	29	29
	L3	29	30	29
	L4	-	-	29

Tab. 24

## Rope anchorage (YKA/SKA - YKC/SKC)

**21**

Fig. 53

**26**

Fig. 54

**22**

Fig. 55

**27**

Fig. 56

	a±0.12 [in]	b±0.12 [in]
YKA	8.5	9.5
YKB	10.4	11.4
YKC	13.1	14.4

Tab. 25

**23**

Fig. 57

	A ±0.12 [in]	b±0.12 [in]
YKA	8.5	9.5
YKB	10.4	11.4
YKC	13.1	14.4

Tab. 26

**28**

Fig. 58

**24**

Fig. 59

**29**

Fig. 60

**25**

Fig. 61

**30**

Fig. 62

\*1 Gear side

# 4 Installation

## Rope anchorage (YKE/SKE)

	Length L	YKE/SKE
2PS	L2-L5	32
4PS	L2-L5	31
1PD		-
2PD	L2-L5	34
4PD	L3-L5	35

Tab. 27

	Length L	YKE/SKE
2PS	L2-L5	32
4PS	L2-L5	31
2PD	L2-L5	34

Tab. 28

	Length L	YKE/SKE
2PS	L2-L5	32
4PS	L2-L5	31
2PD	L2-L5	34
4PD	L3-L5	35

Tab. 29

**31**

F0492

Fig. 63

**32**

F0493

Fig. 64

**34**

F0491

Fig. 65

**35**

W0989

Fig. 66

\*1 Gear side

### 5 Commissioning

The wire rope hoist has been subjected to a final inspection by the manufacturer in accordance with the EC Machinery Directive.

#### WARNING

##### **Safety hazard.**

- Make sure a qualified person performs commissioning.

When the hoist is commissioned and / or after a service call a comprehensive retest must always be performed.

The following checks must be carried out:

1. That the wire rope hoist is completed with the original accessories as supplied (e.g. bottom hook block).
2. Tight fit of the rope on the drum.
3. If the fit is loose:
  - Dismount the rope guide (see page 79, section **7.14.3 “Removing rope guide”**).
  - Tighten up the wire rope on the rope drum and tension.
  - Mount the rope guide (see page 81, section **7.14.5 “Fitting rope guide”**).
4. Correct selection and installation of all electrical equipment.
5. Connecting to mains (see page 45, section **4.9.10 “Connecting to mains”**).
6. Rope reeving, rope twist, fleet angle and angle of installation of wire rope hoist (see page 48, section **4.11 “Reeving rope”**).
7. The screw connections are tightened with the prescribed tightening torque.
8. Correct functioning of runway end stops.

#### WARNING

**Safety hazard.** On three phase hoists, it is possible to have “Reverse Phasing” causing the block to lower when the “UP” button is depressed. When this condition exists, the hoist operation will be dangerous.

9. The direction of motion of the load hook must correspond to the symbols on the control pendant.
10. Presence and correct functioning of all safety devices.
11. Emergency hoist limit switch or combined operational and emergency hoist limit switch, see page 72, section **7.10.6 “Setting hoist limit switch”**
- 12.
13. Run rope in under partial load will improve service life (see page 48, section **4.11 “Reeving rope”**).
14. That the electrical equipment corresponds to the technical documentation
15. Functional test of all control functions and safety circuits (motions, brakes, emergency stop, limit switches).
16. Maximum working load of hoist with test loads (crane test, see page 77, section **7.13. “Crane test”**).
  - Dynamic test:  $1.1 \times$  maximum working load
  - Static test:  $1.25 \times$  maximum working loadThe test loads must be provided by the owner.
17. Function of overload safety device (see page 77, section **7.12 “Overload safety device”**).

The overload safety device cannot be set in the factory if it is provided by others, it must therefore be set during commissioning.
18. Confirm that commissioning has been duly carried out in the logbook.

### 6 Operating

#### **⚠ WARNING**

**Safety hazard.** Bridging limit switches or operating the hoist with a damaged rope or brake is not permissible.

---

#### 6.1 Operating precautions

1. **DO** read the Operation & Service Manual.
2. **DO** read the applicable sections of FEM 9.756, Section IX "SERIES LIFTING EQUIPMENT"
3. **DO** be familiar with hoist operating controls, procedures, and warnings.
4. **DO** make sure that the hook travel is in the same direction as shown on the controls.
5. **DO** maintain firm footing when operating hoist.
6. **DO** make sure that the load slings or other approved attachments are properly sized and seated in the hook saddle.
7. **DO** make sure that the hook latch is closed and not supporting the load.
8. **DO** make sure that load is free to move and will clear all obstructions.
9. **DO** take up slack carefully, check load balance, lift a few inches and check load's holding action before continuing.
10. **DO** avoid swinging load or load hook.
11. **DO** make sure that all persons stay clear of the suspended load.
12. **DO** warn personnel of an approaching load.
13. **DO** protect wire from weld splatter or other damaging contaminants.
14. **DO** promptly report any malfunction, unusual performance or damage of the hoist.
15. **DO** inspect the hoist regularly, replace damaged or worn parts, and keep appropriate records of maintenance.
16. **DO** use hoist manufacturer's recommended parts when repairing a hoist.
17. **DO** use hook latches.
18. **DO** apply lubricant to the wire rope as recommended.
19. **DO NOT** lift more than rated load.
20. **DO NOT** use the hoist load-limiting device to measure the load.
21. **DO NOT** use a damaged hoist or a hoist that is not working properly.
22. **DO NOT** use the hoist with twisted, kinked, damaged, or worn wire rope.
23. **DO NOT** lift a load unless wire rope is properly seated in its groove(s).
24. **DO NOT** use wire rope as a sling or wrap rope around the load.
25. **DO NOT** lift a load if any binding prevents equal loading on all supporting ropes.
26. **DO NOT** apply the load to the tip of the hook.
27. **DO NOT** operate unless load is centered under hoist.
28. **DO NOT** allow your attention to be diverted from operating the hoist.
29. **DO NOT** operate the hoist beyond limits of wire rope travel.
30. **DO NOT** use limit switches as routine operating stops unless recommended. They are emergency devices only.
31. **DO NOT** use the hoist to lift, support, or transport people.
32. **DO NOT** lift loads over people.
33. **DO NOT** leave a suspended load unattended unless specific precautions have been taken.
34. **DO NOT** allow sharp contact between two hoists or between hoist and obstructions.

35. **DO NOT** allow the rope or hook to be used as a ground for welding.
36. **DO NOT** allow the rope or hook to be touched by a live welding electrode.
37. **DO NOT** remove or obscure the warnings on the hoist.
38. **DO NOT** adjust or repair a hoist unless qualified to perform hoist maintenance.
39. **DO NOT** attempt to lengthen the wire rope or repair damaged wire rope.
40. **DO NOT** allow personnel not physically fit or properly qualified, to operate hoist.
41. **DO NOT** operate hoists unless hook moves in the same direction as indicated on the push button. If opposite direction occurs, see pre-operation checks, Section II Paragraph 2-4.b.
42. **DO NOT** operate hoist unless limit switches are operating properly.
43. **DO** avoid operating hoist when hook is not centered under hoist. Avoid side pulls and swinging of load or load hook when traveling hoist.
44. **DO** operate hoist within recommended duty cycle and **DO NOT** jog unnecessarily.
45. **DO** conduct regular visual inspections for signs of damage and wear.
46. **DO NOT** operate the hoist with hooks that have opened up.
47. **DO** provide supporting structure that has an appropriate design factor based on the load rating and dead weight of the hoist. If in doubt of the supporting structure's strength, consult a structural engineer.
48. **DO NOT** use hoist in location that will not allow operator movement to be free of the load.
49. **DO**, when starting to lift, move the load a few inches at which time the hoist should be checked for proper load holding action. The operation shall be continued only after the operator is assured that the hoist is operating properly and that the load is supported in the center of the base bowl/saddle of the hook.
50. **DO** observe recommended inspection and maintenance procedures.
51. **DO** use common sense and best judgment whenever operating a hoist.
52. **DO NOT** remove drop lugs. Removal will create an unsafe operating condition.
53. **DO NOT** lift guided loads.

### 6.2 Duties of crane operator

**Personal protective equipment must be provided by the owner.**

#### **Requirements for workplace**

1. The operator must not stand in the hazard area.
2. The hazard area must be clearly visible.
3. The movement of the load in all directions must be clearly visible.

#### **⚠ WARNING**

#### **Safety hazard.**

When working with wire rope hoists, the following points must be observed:

1. The crane operator must observe the load, or if the crane is unloaded, the load suspension equipment during all movements of the crane if they could cause danger. If it is not possible to observe the crane, the crane operator may only control the crane by following signals from a signaller.
2. Wear ear protectors in noisy environments.
3. Start lifting load with the slowest hoisting speed.
4. The crane operator must give warning signals as necessary.
5. Loads attached by hand may only be moved by the crane operator after an unambiguous signal from the person attaching the load, the signaller or another person responsible appointed by the owner. If signals need to be used to communicate with the crane operator they must be agreed between the person responsible and the crane operator before being used.
6. Every day before starting work, check brakes and limit switches and inspect the system for any visible defects.
7. Stop working with the crane if there are any defects which might prejudice its safety in operation.
8. At close of work, secure cranes which are exposed to wind with the wind safeguard mechanism.
9. The rope drum and rope must be free of coarse foreign matter.
10. Do not move loads above people.
11. Before starting work, ensure there is sufficient workspace.
12. Do not leave suspended loads unattended, the control pendant must be within easy reach.
13. Do not activate emergency hoist limit switch during normal operation.
14. Do not load above the permitted maximum working load.
15. Use only tested and approved sling equipment
16. Pulling loads at angles, dragging loads, or towing vehicles with the load or load suspension equipment is forbidden!
17. Do not jerk free any loads which are jammed.
18. Approach final positions for hoisting, lowering and travel in normal operation only if an operational hoist limit switch is fitted.
19. Inching operation (repeated brief activation of the motor to achieve small movements) is not permissible. Motors and brakes could be subjected to an impermissible temperature rise. This would lead to the temperature control disconnecting and the load could then not be set down for some time. Switchgear and motors could be damaged.
20. Do not move in the opposite direction until the hoist has come to a stop.
21. Observe the safety instructions in this manual.



### 6.3 Using control pendant

#### **▲ WARNING**

##### **Danger of unintentional movement of hoist**

If the rocker switch is no longer depressed by the operator, it returns to the 0 position, the hoist motion is automatically stopped (dead man's control).

If the hoist malfunctions, e.g. the actual motion does not correspond to the motion intended in activating the rocker switch, release the rocker switch immediately. If the motion continues, press the emergency stop.

If this also fails to bring the hoist to a standstill, the emergency stop switch (mains connection switch) should be immediately switched off and secured to prevent re-activation.

#### STH

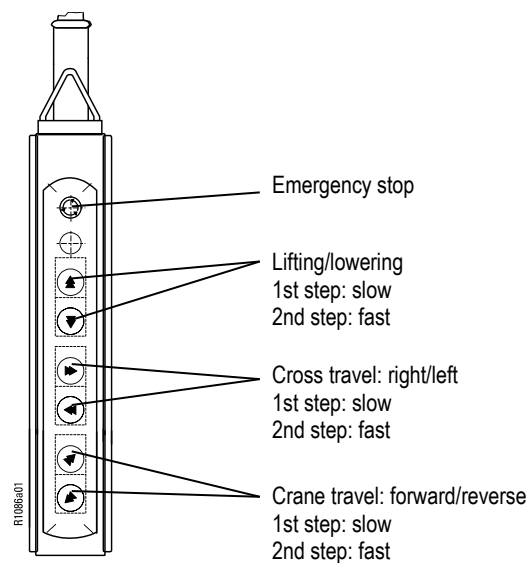

Fig. 67

## 6.4 Operating hoist with frequency inverter

- 1st step: slow
- 2nd step: accelerate

When the 1st step is activated, the hoist is accelerated to slow speed and slow speed is maintained. When the 2nd step of the pushbutton is activated, the hoist is accelerated as long as the 2nd step is activated or until maximum speed is reached. If the pushbutton is returned from 2nd step to 1st step before maximum speed is reached, the current speed is maintained. If the pushbutton is then released, the speed is reduced. If the 1st step is activated before the motion is stopped, the current speed is maintained.

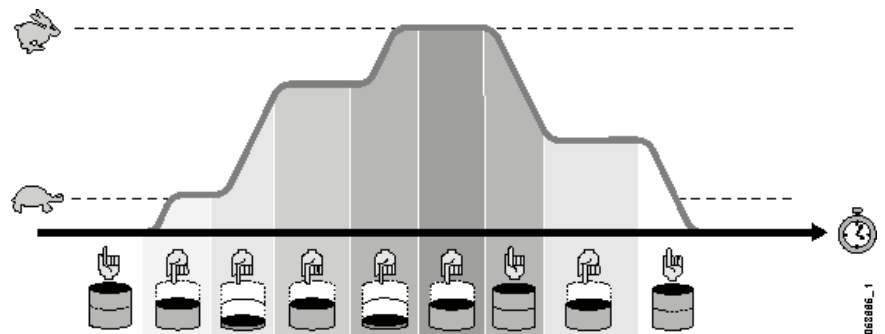

Fig. 68

## 6.5 Emergency stop

### ▲ WARNING

**Safety hazard.** After an emergency stop, the operator must not restart the hoist /crane system until a qualified person has determined that the fault which led to this function being activated has been eliminated and no danger can arise from the continued operation of the system.

Every hoist must have a means of disconnecting the power supply to all drives under load from the ground.

The emergency stop is on the control pendant.

1. Press emergency stop button, the system comes to a halt.
2. To release the emergency stop:
  - on STH: turn the button in the direction shown

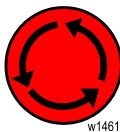

Fig. 69

### 7 Inspection and maintenance

This section deals with operational reliability, availability, and maintaining the value of your wire rope hoist.  
Although this wire rope hoist is practically maintenance-free, the components subject to wear (e.g. wire rope, brake) must be inspected regularly.  
Inspection and maintenance must be carried out by qualified persons.

#### WARNING



#### Falling parts hazard.

- Cordon off and secure danger area before inspection and maintenance work.

#### General information on inspection and maintenance

1. Make sure a qualified person performs inspection and maintenance.
2. Perform maintenance and repair work only when the hoist is unloaded.
3. Before starting disconnect power and implement a Lockout/Tagout (LOTO) procedure before servicing the equipment.
4. Check that the hoist is de-energized.
5. Perform periodic inspections including maintenance every 12 months, possibly earlier if so prescribed by national regulations like ASME B30.16.

**NOTE:** The specified inspection and maintenance intervals apply for normal conditions of use.

If major components are replaced, further tests must be performed.

- Replacing components of the overload safety device (sensor, electronic overload device)  
For load test of cut-off values of system, see separate Operating instructions / Service manual
- Replacement of electrical equipment and renewal of electric leads and connections  
Insulation resistance test and testing the continuity of the PE system
- Correct phase connection

The hoist's electrical equipment must be checked regularly. Damage to electrical equipment, loose terminals, damaged cables and worn switchgear contacts must be remedied immediately.

The inspection and maintenance intervals must be adapted accordingly if one or more the following conditions apply:

- If after evaluating the actual use it can be seen that the theoretical useful life of the hoist will be less than 10 years.
- In the case of operation in more than one shift or heavy duty.
- In the case of adverse conditions (dirt, solvents, temperature, etc.).
- If abrasive dusts are present (foundry, cement industry, glass manufacture or processing, etc.) the maintenance intervals for the rope guide (cleaning, lubricating, checking and if necessary replacing tension spring, etc.) must be reduced.
- A general overhaul must be carried out after the useful lifetime has expired.
- Lubricants and lubrication points, see section "**Lubricants**".

## 7 Inspection and maintenance

### 7.1 Inspection intervals

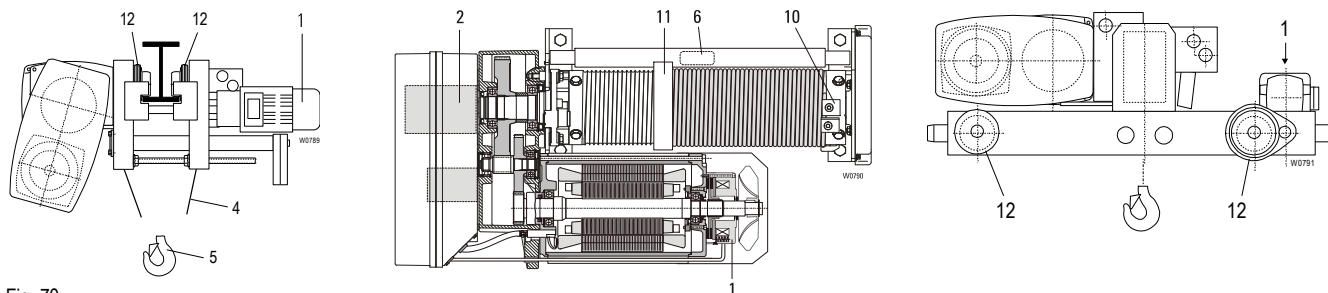

Fig. 70

Test every day before starting work *1	Periodic inspection every 12 months *2	Inspection table	see page
•	•	Function of brakes (1) with regard to braking efficiency and activation	
•	•	Emergency hoist limit switch (2), if there is no operational hoist limit switch, operational hoist limit switch, if any	70
•	•	Emergency stop, travel limit switches, crane switch	42
•	•	Rope (4)	78
•	•	Check state of system for obvious defects	
	•	Check suspension of control pendant (cable and steel wire must be correctly attached)	
	•	Load hook (5), cracks, distortion, wear, corrosion, function of hook safety latch	
	•	Overload safety device (6)	77
	•	Disconnect switch and main isolator	42
	•	PE connections and equipotential bonding	
	•	Establish remaining service life	86
	•	Rope attachment (10) and rope sheaves	78, 83
	•	Rope guide (11)	79, 81
	•	Drive parts (12), wheel flanges, wheels etc.	85
	•	Bolt joints, welds	
	•	End stops, buffers	
	•	Safety clearances	
	•	Power supply cable	
	•	Cable glands	
	•	Towing arm	
	•	Switching functions	
	•	All parts in the power flux	

\*1 By user

- i** Periodic inspections including maintenance at least every 12 months, possibly more frequently if so prescribed by national regulations, to be performed by a qualified person.
- \*2 Heavy duty or unfavorable conditions (dirt, solvents, multi-shift operation, etc.) entail a reduction of this inspection and maintenance interval.

#### **▲ WARNING**

**Safety hazard.** If work needs to be carried out on live parts, a second person must be present who can stop dangerous movements in an emergency by means of the emergency stop or disconnect the power supply by means of the main isolator / disconnect switch.

# 7 Inspection and maintenance

## 7.2 Maintenance intervals

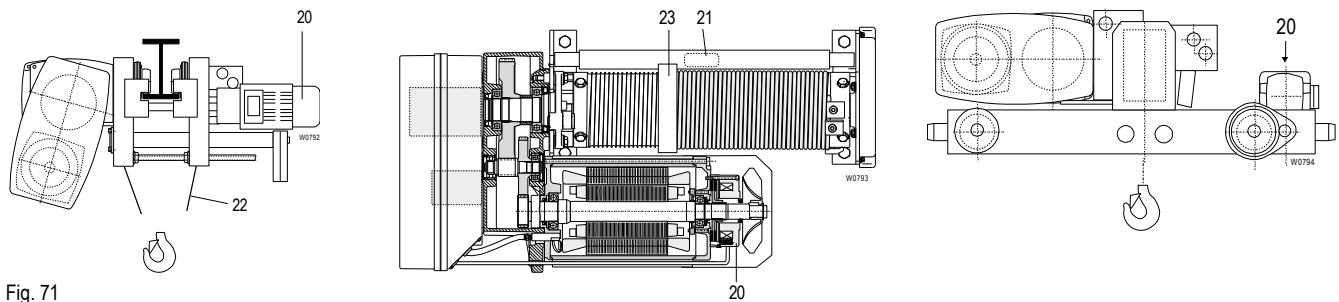

Fig. 71

Periodic inspection every 12 months *2	Work every 5 years	Work every 10 years	Maintenance table	see page
•			Brake (20), measure air gap, replace brake disk if necessary	63, 64, 65
•			Overload safety device (21)	77
•			Grease rope (22) with brush	101
•			Grease rope guide (23) with brush	101
•			Tighten clamping points for electric cables	
		•	Oil change (normal mode)	101
	•		Oil change in case of ambient temperatures $\geq 131^{\circ}\text{F}$ and engine rating M7 and higher	101

**i** Periodic inspections including maintenance at least every 12 months, possibly more frequently if so prescribed by national regulations, to be performed by a qualified person. \*2 Heavy duty or unfavorable conditions (dirt, solvents, multi-shift operation, etc.) entail a reduction of this inspection and maintenance interval.

### NOTICE

**Material damage hazard.** If increased wear or damage is ascertained when inspecting or maintaining the hoist, the latter must not be put into operation again until the faults have been eliminated.

### 7.3 Motors



#### **⚠ DANGER**

**Electric shock hazard.** Some motor parts are live. Any contact with live parts can cause severe injury or death. Motors have dangerous rotating parts and hot surfaces.

---

Ensure that:

- the motor runs correctly (e.g. no variations in speed, no noise emission),
- there are no strong vibrations.

The insulation resistance must be checked after a long period of storage or shutdown, if possible at a winding temperature of +68°F ... +86°F. Before starting to measure the insulation resistance, pay attention to the operating instructions of the insulation measurement instrument being used.

Measuring voltage: 500 V.

Minimum insulation resistance for new, cleaned or overhauled windings: 10 MΩ.

Critical specific insulation resistance after a long period of operation: 0.5 MΩ / kV.

If the critical insulation resistance is reached or undershot, the windings must be dried, or thoroughly cleaned and dried after removing the rotor.

## 7 Inspection and maintenance

### 7.4 Hoist motor brake (RSM)

This inspection and maintenance is of particularly important to ensure safety. If brake maintenance is not performed correctly or the brake does not function correctly, the load may fall!

#### ⚠ WARNING



#### Falling load hazard.

- Carry out work on the hoist brake only when the hoist is unloaded and the bottom hook block has been set down.
- Before starting disconnect power and implement a Lockout/Tagout (LOTO) procedure before servicing the equipment.

#### 7.4.1 Checking brake

1. Remove fan cover (1)
2. Remove plug (2)
3. Measure air gap (S) with feeler gage (F).

**NOTE:** When measuring, ensure that the feeler gage is pushed in at least as far as depth “a” (see Tab. 30) and does not catch on shoulder (!). See Tab. 30 for max. permissible air gap (S). The brake is not adjustable. If the max. permissible air gap (S) has been reached, the brake disk (brake rotor) must be replaced.

#### 7.4.2 Replacing brake disk (brake rotor)

1. Remove fan cover (1)
2. Pull off fan wheel (3), remove feather key
3. Disconnect brake
4. Unscrew fixing screws (4)
5. Remove magnet piece (5) together with armature disc (6)
6. Remove brake disk (brake rotor) (7)
7. Clean brake (wear a dust protection mask)
8. Check friction surfaces for wear
9. Push new brake disk (brake rotor) (7) onto hub (8) and check radial play. If there is increased play in the gearing between brake disk (7) and hub (8) the hub (8) must be pulled off the motor shaft and replaced.
10. Check torsional backlash of motor shaft. If the play is above 3°, check rotor hub and shaft and replace worn parts.

#### NOTICE

**Material damage hazard.** Always contact the manufacturer before removing the hub (8).

11. Replace in reverse order.
12. Ensure that the check hole for measuring the air gap is underneath.
13. Observe tightening torques of fixing screws (4) (see following table).

Hoist motor type	Hoist brake	Smax.	a	Tightening torque [lb: ft]
		[in]	[in]	
12/2H73	RSM150	0.063	1.2	16
24/4H92	RSM500	0.079	1.6	33

Tab. 30

14. Check brake data according to rating plate on hoist motor!

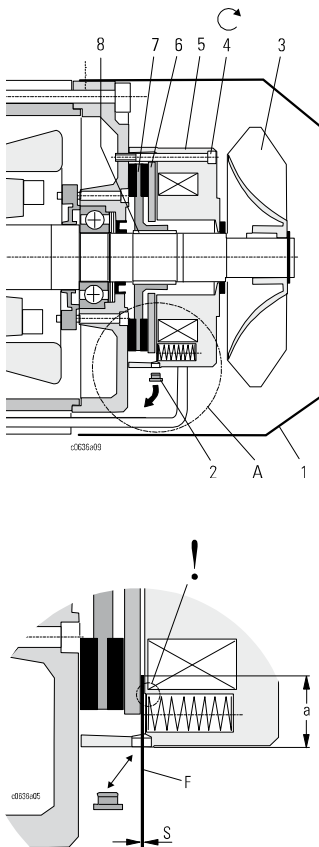

Fig. 72

## 7.5 Hoist motor brake (NM) (pole-changing)



### WARNING

#### Falling load hazard.

- Carry out work on the hoist brake only when the hoist is unloaded and the bottom hook block has been set down.
- Before starting disconnect power and implement a Lockout/Tagout (LOTO) procedure before servicing the equipment.

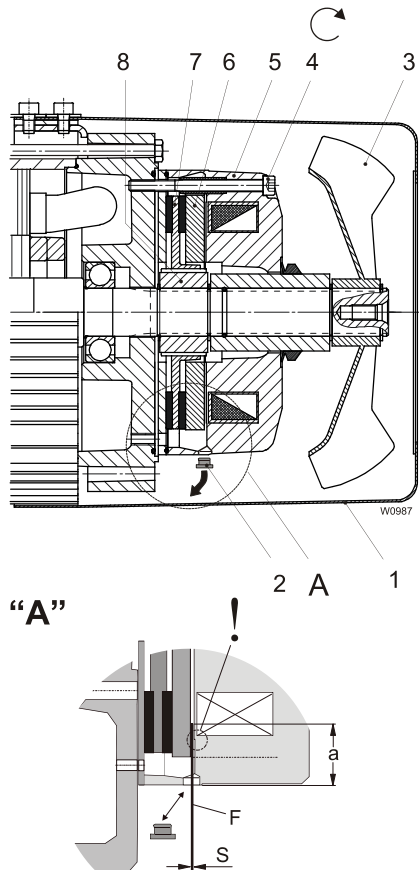

Fig. 73

### 7.5.1 Checking brake

1. Remove fan cover (1)
2. Remove plug (2)
3. Measure air gap (S) with feeler gage (F).

**NOTE:** When measuring, ensure that the feeler gage is pushed in at least as far as depth "a" (see Tab. 31) and does not catch on shoulder (!). See Tab. 31 for max. permissible air gap (S). The brake is not adjustable. If the max. permissible air gap (S) has been reached, the brake disk (brake rotor) must be replaced.

### 7.5.2 Replacing brake disk (brake rotor)

1. Remove fan cover (1)
2. Pull off fan wheel (3), remove bushing with V-ring (IP 66)
3. Disconnect brake
4. Unscrew fixing screws (4)
5. Remove magnet piece (5) together with armature disc (6)
6. Remove brake disk (brake rotor) (7)
7. Clean brake (wear a dust protection mask)
8. Check friction surfaces for wear
9. Push new brake disk (brake rotor) (7) onto hub (8) and check radial play. If there is increased play in the gearing between brake disk (7) and hub (8) the hub (8) must be pulled off the motor shaft and replaced.

### NOTICE

**Material damage hazard.** Always contact the manufacturer before removing the hub (8).

10. Replace in reverse order.
11. Ensure that the check hole for measuring the air gap is underneath.
12. Observe tightening torques of fixing screws (4) (see following table).

Hoist motor type	Hoist brake	Smax.	a	Tightening torque
		[in]	[in]	[lb <sub>r</sub> ft]
12/2H33-MF10Z-106	NM38722	0.024	1	7
12/2H42-MF10X-106	NM38732	0.024	1	7
12/2H62-MF11X-106	NM38742	0.031	1	16
12/2H71-MF11X-106	NM38742	0.031	1	16
12/2H72-MF13Z-106	NM38754	0.035	1.2	16
12/2H91-MF16ZC-106	NM38790	0.035	1.6	33

Tab. 31

1. Check brake data according to rating plate on hoist motor!



## 7.6 Hoist motor brake (NM) (4-pole)

### WARNING



#### Falling load hazard.

- Carry out work on the hoist brake only when the hoist is unloaded and the bottom hook block has been set down.
- Before starting disconnect power and implement a Lockout/Tagout (LOTO) procedure before servicing the equipment.

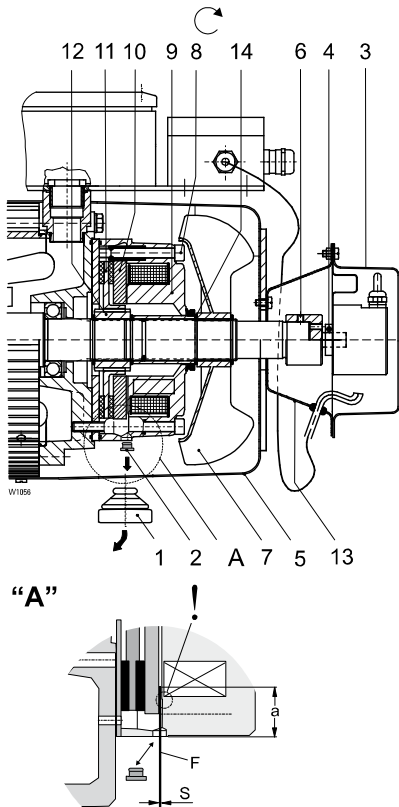

Fig. 74

### 7.6.1 Checking brake

1. Remove plug (1)
2. Remove plug (2) with pliers
3. Measure air gap (S) with feeler gage (F).

**NOTE:** When measuring, ensure that the feeler gage is pushed in at least as far as depth "a" (see Tab. 32) and does not catch on shoulder (!). See Tab. 32 for max. permissible air gap (S). The brake is not adjustable. If the max. permissible air gap (S) has been reached, the brake disk (brake rotor) must be replaced.

### 7.6.2 Replacing brake disk (brake rotor)

1. Remove cover of housing (3)
2. Unscrew stud screw (4) (short hexagon socket s2)
3. Pull off shaft encoder and leave it hanging on the connecting cable
4. Remove bottom section of housing (13)
5. Remove fan wheel (5)
6. Unscrew stud screws (6) on adapter shaft
7. Remove adapter shaft with lifting screws (M6)
8. Remove circlip from fan wheel
9. Pull off fan wheel (7), remove V-ring (IP66)
10. Remove circlip (14)
11. Disconnect brake
12. Remove fixing screws (8)
13. Remove magnet piece (9) together with armature disc (10)
14. Remove brake rotor (11)
15. Clean brake (wear a dust protection mask)
16. Check friction surfaces for wear
17. Push new brake disk (brake rotor) (11) onto hub (12) and check play. If there is increased play in the gearing between brake disk (11) and hub (12) the hub (12) must be pulled off the motor shaft and replaced.

### NOTICE

**Material damage hazard.** Always contact the manufacturer before removing the hub (12).

18. Replace in reverse order.
19. Ensure that the check hole for measuring the air gap is aligned with the opening in the fan wheel cover.
20. Lock stud screws (6) with locking varnish.
21. Observe tightening torques of fixing screws (8) (see table below).

Hoist motor type	Hoist brake	Smax.	a	Tightening torque
		[in]	[in]	[lb <sub>f</sub> ft]
4H33-MF10MB-200	NM38720	0.024	1	7
4H42-MF10MC-200	NM38730	0.024	1	7
4H62-MF11MA-200	NM38740	0.031	1	16
4H71-MF11MB-200	NM38740	0.031	1	16
4H72-MF13Z-200	NM38741	0.031	1.2	16
4H73-MF13ZB-200	NM38753	0.035	1.2	16
4H81-MF13ZC-200	NM38753	0.035	1.2	16
4H82-MF13X-200	NM38781	0.035	1.2	16

Tab. 32

22. Check brake data according to rating plate on hoist motor!

## 7 Inspection and maintenance

### 7.7 Hoist motor brake (NM) 4HS.



#### WARNING

##### Falling load hazard.

- Carry out work on the hoist brake only when the hoist is unloaded and the bottom hook block has been set down.
- Before starting disconnect power and implement a Lockout/Tagout (LOTO) procedure before servicing the equipment.

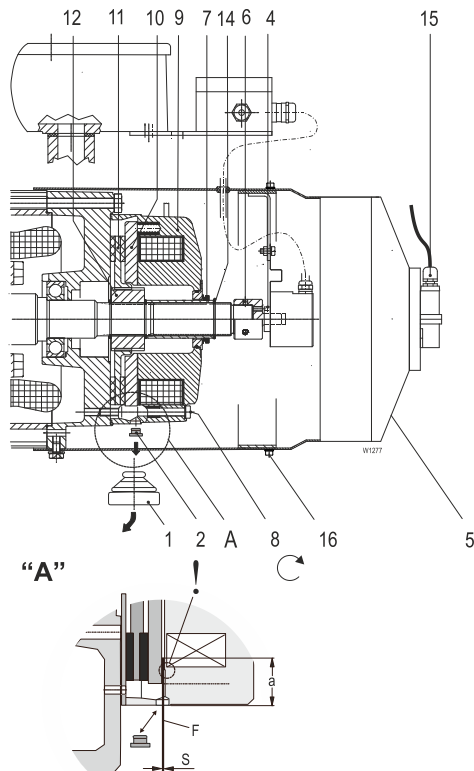

Fig. 75

#### 7.7.1 Checking brake

1. Remove plug (1)
2. Remove plug (2) with pliers
3. Measure air gap (S) with feeler gage (F).
4. **NOTE:** When measuring, ensure that the feeler gage is pushed in at least as far as depth "a" (see Tab. 33) and does not catch on shoulder (!). See Tab. 33 for max. permissible air gap (S). The brake is not adjustable. If the max. permissible air gap (S) has been reached, the brake disk (brake rotor) must be replaced.

#### 7.7.2 Replacing brake disk (brake rotor)

1. Remove plug (15)
2. Remove fixing screws (16)
3. Remove forced ventilation (5)
4. Unscrew stud screw (4) (short hexagon socket s2)
5. Pull off shaft encoder and leave it hanging on the connecting cable
6. Unscrew stud screws (6) on adapter shaft
7. Remove adapter shaft with lifting screws (M6)
8. Remove V-ring (7) (IP66)
9. Remove circlip (14)
10. Disconnect brake
11. Remove fixing screws (8)
12. Remove magnet piece (9) together with armature disc (10)
13. Remove brake rotor (11)
14. Clean brake (wear a dust protection mask)
15. Check friction surfaces for wear
16. Push new brake disk (brake rotor) (11) onto hub (12) and check play. If there is increased play in the gearing between brake disk (11) and hub (12) the hub (12) must be pulled off the motor shaft and replaced.

#### NOTICE

**Material damage hazard.** Always contact the manufacturer before removing the hub (12).

## 7 Inspection and maintenance

---

17. Replace in reverse order.
18. Ensure that the check hole for measuring the air gap is aligned with the opening in the fan wheel cover.
19. Lock stud screws (6) with locking varnish.
20. Observe tightening torques of fixing screws (8) (see following table).

Hoist motor type	Hoist brake	Smax.	a	Tightening torque
		[in]	[in]	[lb <sub>r</sub> ft]
4HS3	NM38730	0.024	1	7
4HS5	NM40940	0.031	1	16
4HS7	NM40951	0.031	1.2	16
4HS8	NM40980	0.035	1.2	16
4HSA	NM40980	0.035	1.2	16

Tab. 33

21. Check brake data according to rating plate on hoist motor!

### 7.8 Travel motor brake

See instructions for travel motors.

# 7 Inspection and maintenance

## 7.9 Hoist limit switch



The hoist limit switch layout installed must be determined on the basis of the sticker in the limit switch (see stickers).  
More free switching elements, hoist limit switch layouts are possible as an option (see circuit diagram)

### 7.9.1 Hoist limit switch (standard)

**Version 1:** Operational limit switch for top hook position (standard on YK/SK)

Description of system see next section.

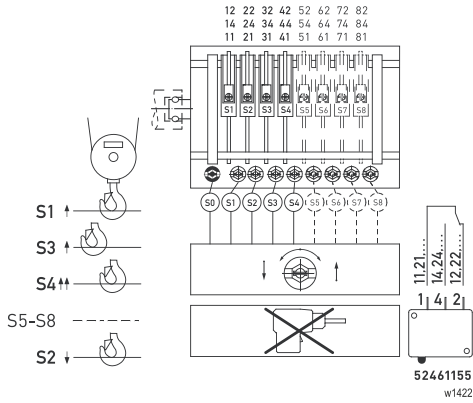

Fig. 76

**Version 2:** Operational hoist limit switch for top and bottom hook position (standard on YK/SK with VFD, option on YK/SK)

Description of system see next section.

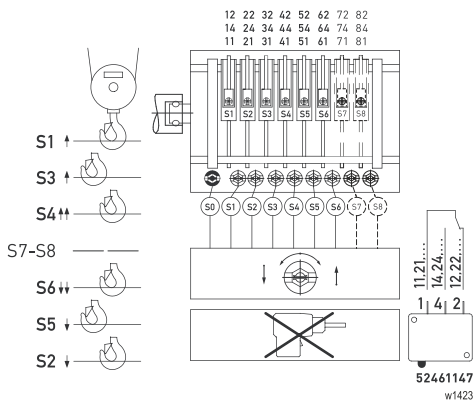

Fig. 77

## 7.10 Hoist limit switch

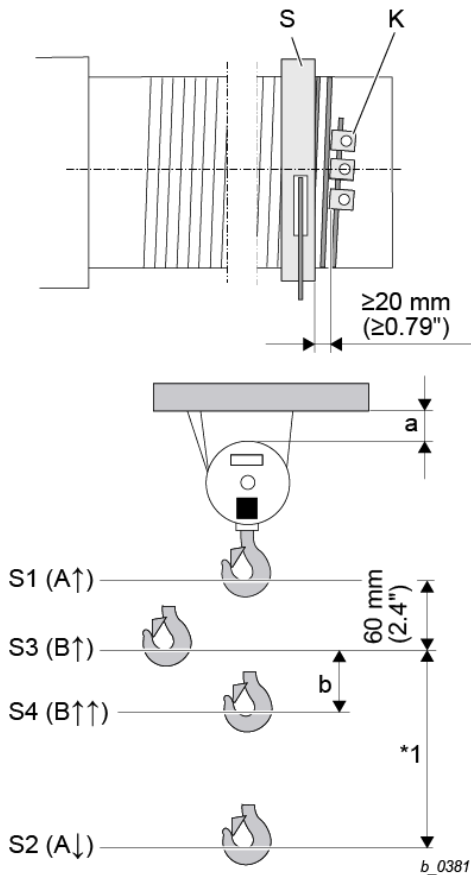

Fig. 78  
\*1 Effective hook path

Wire rope hoist type YK/SK	Minimum clearance a [in]	
	50 Hz	60 Hz
1PS 1PD	5.1	5.9
2PS 2PD	2.8	3.1
4PS	1.6	2

Tab. 34

### 7.10.1 Description of hoist limit switch system

- The wire rope hoist is equipped as standard with an emergency hoist limit switch for disconnecting in top and bottom hook position (switching points A↑ and A↓).
- The hoist is also equipped with an operational hoist limit switch for disconnecting in top hook position during normal operation (switching points B↑ and B↑↑).
- Switching point B↑↑ disconnects the fast speed and B↑ the slow speed in upwards direction.
- If the operational limit switch (B↑, B↑↑) is overrun during a malfunction, the emergency hoist limit switch (A↑) disconnects the main contactor / hoist contactor. The hoist can only leave the hoist limit switch area by activating switch S261 in the hoist control after the fault has been eliminated.
- The hoist limit switch (S220) is in the panel box on the gear.
- For version 2, an additional operational hoist limit switch for disconnecting in bottom hook position during normal operation is fitted as an option (switching points B↓, B↓↓).
- Switching point B↓↓ disconnects the fast speed and B↓ the slow speed in downwards direction.
- If the operational limit switch (B↓, B↓↓) is overrun during a malfunction, the emergency hoist limit switch (A↓) disconnects the main contactor / hoist contactor. The hoist can only leave the hoist limit switch area by activating switch S261 in the hoist control after the fault has been eliminated.

### 7.10.2 Testing emergency hoist limit switch, version 1

1. Test at slow speed without load.
2. Activate the **“up” button** on the control pendant carefully, observing the hoisting motion, until the hoist limit switch disconnects in the highest operational hook position (B↑).
3. Activate the override button (S260) in the control and at the same time the **“up” button** until the emergency hoist limit switch disconnects (A↑). If the hoist does not continue to move, the emergency hoist limit switch has already switched off in step 1 and the operational hoist limit switch is not functioning.
4. Minimum clearance **“a”** between bottom hook block and the nearest obstacle, see Tab. 34, or hook dimension **C -2.4 in**, see Tab. 37, page 76 must be maintained at least, depending on which dimension is larger.
5. Activate the override button (S261) in the control panel and at the same time the **“down” button** to leave the hoist limit switch area.
6. Activate the **“down” button** on the control pendant until the emergency hoist limit switch disconnects (A↓).
7. Minimum clearance between rope guide (S) and clamping claws (K) for rope anchorage = **0.79 in**, if necessary reset hoist limit switch (see page 72, section 7.10.6 **“Setting hoist limit switch”**).

### 7.10.3 Testing operational hoist limit switch, version 1

1. Test without load.
2. Activate the **“up” button** on the control pendant carefully, observing the hoisting motion, until the hoist limit switch disconnects in the highest operational hook position (B↑).
3. The hoist must be switched over to slow speed (B↑↑) before reaching cut-off point (B↑).
4. Minimum clearance **a + 2.4 in** between bottom hook block and the nearest obstacle, (see table above left), or the hook dimension **“C”**, see Tab. 37, page 76 must be maintained at least, depending on which dimension is greater. If necessary reset hoist limit switch, see page 72.

The clearances between the switching points for operational and emergency hoist limit switches are set for normal operating conditions, however they can be increased if necessary.

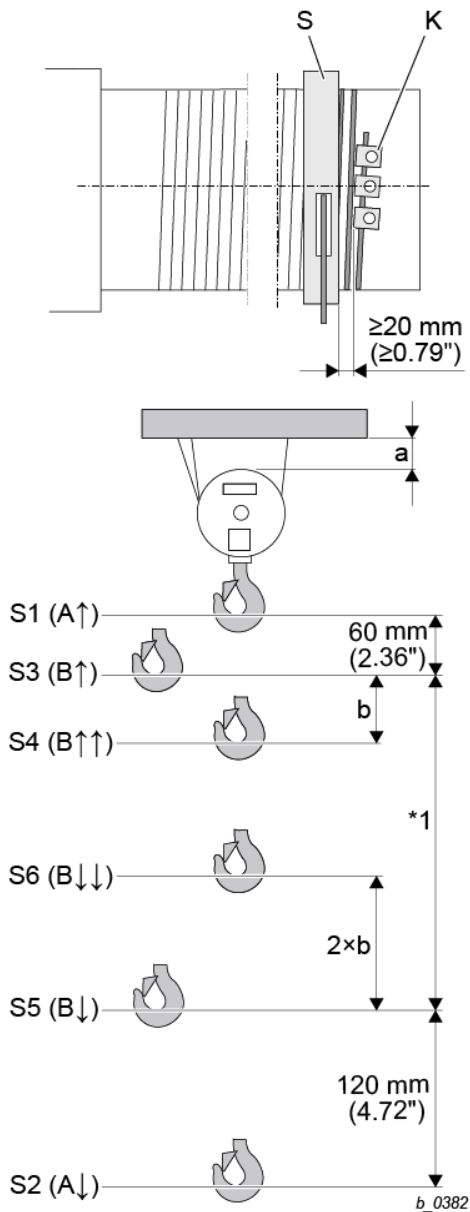

Fig. 79  
\*1 Effective hook path

## 7.10.4 Testing emergency hoist limit switch, version 2

1. Test at slow speed without load.
2. Activate the **“up”** button on the control pendant carefully, observing the hoisting motion, until the hoist limit switch disconnects in top operational hook position (B↑).
3. Activate the override button (S260) in the control and at the same time the **“up”** button until the emergency hoist limit switch disconnects (A↑). If the hoist does not continue to move, the emergency hoist limit switch has already switched off in step 1 and the operational hoist limit switch is not working.
4. Minimum clearance **“a”** between bottom hook block and the nearest obstacle, see tab. 36. or the hook dimension **C -2.4 in.**, see Tab. 37, page 76 must be maintained at least, depending on which dimension is larger (see page 72, section 7.10.6 **“Setting hoist limit switch”**).
5. Activate the override button (S261) in the control panel and at the same time the **“down”** button to leave the limit switch area.
6. Activate the **“down”** button on the control pendant carefully, observing the hoisting motion, until the hoist limit switch disconnects in bottom operational hook position (B↓).
7. Activate the override button (S262) in the control and at the same time the **“up”** button until the emergency hoist limit switch disconnects (A↓). If the hoist does not continue to move, the emergency hoist limit switch has already switched off in step 5 and the operational hoist limit switch is not working.
8. Minimum clearance between rope guide (S) and clamping claws (K) for rope anchorage = **0.79 in**, see Fig. 79, if necessary reset hoist limit switch (see page 72, section 7.10.6 **“Setting hoist limit switch”**).
9. Activate the override button (S261) in the control panel and at the same time the **“up”** button to leave the limit switch area.

## 7.10.5 Testing operational hoist limit switch, version 2

1. Test without load.
2. Activate the **“up”** button on the control pendant carefully, observing the hoisting motion, until the hoist limit switch disconnects in the highest operational hook position (B↑). Ensure that the hoist switches over to slow speed (B↑↑) before reaching cut-off point (B↑).
3. Minimum clearance **a+2.4 in.** between bottom hook block and the nearest obstacle, see Tab. 34, or the hook dimension **“C”**, see Tab. 37, page 76 must be maintained at least, depending on which dimension is greater. If necessary reset hoist limit switch, see page 72.
4. Activate the **“down”** button on the control pendant carefully, observing the hoisting motion, until the hoist limit switch disconnects in the highest operational hook position (B↓). Ensure that the hoist switches over to slow speed (B↓↓) before reaching cut-off point (B↓).
5. Minimum clearance 4.7 in between switching points (B↓) and (A↓), (see illustration on the left)
6. If necessary reset hoist limit switch (see page 72, section 7.10.6 **“Setting hoist limit switch”**).

## 7.10.6 Setting hoist limit switch

**⚠ DANGER**



### Electric shock hazard

The cover of the hoist limit switch must be removed to set the contacts. This exposes live contact connections. Make sure an electrical qualified person performs the work.

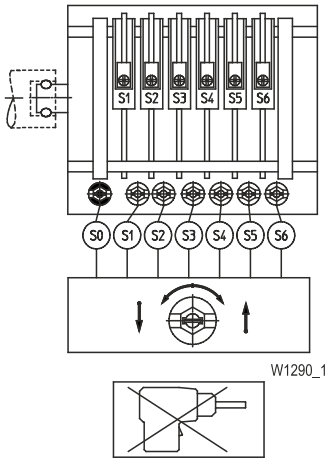

Fig. 80

Adjust hoist limit switch at the setscrews (S1) - (S6) depending on version:

Turning to the left: switching point is moved “downwards”.

Turning to the right: switching point is moved “upwards”.

### Adjusting en bloc

All the cam discs can be moved together with the aid of the black setscrew (S0). The settings of the individual contacts relative to one another remain unchanged (see Fig. 80).

**Set the limit switch using socket spanner (04 430 50 99 0) and without using undue force. Do not use a power screwdriver.**

Adjust the switching points in the following sequence:

1. A↑ (S1)
2. B↑ (S3)
3. B↑↑ (S4)
4. A↓ (S2)
5. B↓ (S5) (option)
6. B↓↓ (S6) (option)

When setting the hoist limit switch, observe hook dimension “C” as specified on page 76, section 7.11 “Hook dimensions C for KE-S.. trolleys”.

### Switching point A↑ (S1)

#### Emergency hoist limit switch top hook position

1. Set without load in creep lifting.
2. Lift bottom hook block to  $a+0.39$  in. (see illustration left and table below) or the hook dimension  $C-2$  in. see Tab. 37, page 76, depending on which dimension is greater. If necessary turn setscrew (S1) to the right beforehand.
3. Turn setscrew (S1) to the left until contact S1 switches audibly.
4. Activate override button (S261) in control panel and at the same time “down” button to leave the hoist limit switch area.
5. Check cut-off point at fast and slow speed.

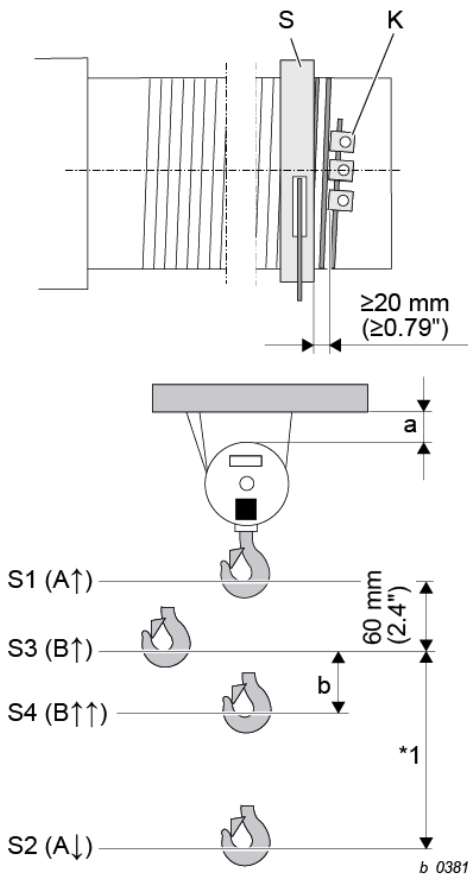





Fig. 81  
\*1 Effective hook path

Wire rope hoist type YK/SK	a [in]	
	50 Hz	60 Hz
 1PS 1PD	5.1	5.9
 2PS 2PD	2.8	3.1
 4PS	1.6	2

Tab. 35



## 7 Inspection and maintenance

Formula:  $b = V \times t \times 0.023 \text{ ft}$

V = Hoist speed [fpm]  
(YKC/SKC-L05-...S262-V)

t = Brake ramp [s]  
1.5s (factory setting)

Type	b
on YK/SK	$b = a$
on YK/SK with VFD	b as per formula

Tab. 36

Example: YKC/SKC-L05-...S262-V  
 $b = 62 \times 1.5 \times 0.023 = 2.14 \text{ ft}$

### Switching point B↑/B↑↑ (S3/S4)

(minimum clearance between B↑ and A↑ 2.4 in.)

1. Lift bottom hook block to **0.39 in.** before the desired cut-off point, if necessary turn setscrew (S3) to the right beforehand.
2. Turn setscrew (S3) to the left until contact S3 switches audibly.
3. Lower and lift bottom hook block until B↑ (S3) switches.
4. YK/SK model: lower bottom hook block by "**b**" (Fig. 81, Tab. 35+Tab. 36).  
YK/SK with VFD model: use formula to calculate clearance "**b**" between (B↑↑) and (B↑).  
The factory setting of the brake ramp (t) is 1.5 s.  
The switching point (B↑↑) is dependent on hoist speed (V) and brake ramp (t).  
If brake ramp (t) is altered, clearance "**b**" must be recalculated and reset.  
Lower bottom hook block by "**b**".
5. Turn setscrew S4 to the left until contact S4 switches audibly.
6. Check cut-off point at fast and slow speed.
7. Ensure that hoist switches over to slow speed before cut-off point (B↑) is reached.

### Switching point A↓ (S2)

#### Emergency hoist limit switch bottom hook position

(Minimum clearance between rope guide (S) and clamping claws (K) for rope attachment = **0.79 in.**, see Fig. 81 (for the rope fastening))

Set bottom hook position so that the bottom hook block does not touch the ground (would cause slack rope).

1. Set without load in creep lifting.
2. Lower bottom hook block to desired hook position, if necessary turn setscrew (S2) to the left beforehand. Observe minimum clearances/lowest hook position.
3. Turn setscrew (S2) to the right until contact S2 switches audibly.
4. Only for option with operational hoist limit switch for bottom hook position!  
Activate override button (S261) in control panel and at the same time the "**up**" button to leave the limit switch area.
5. Check cut-off point at fast and slow speed.

## 7 Inspection and maintenance

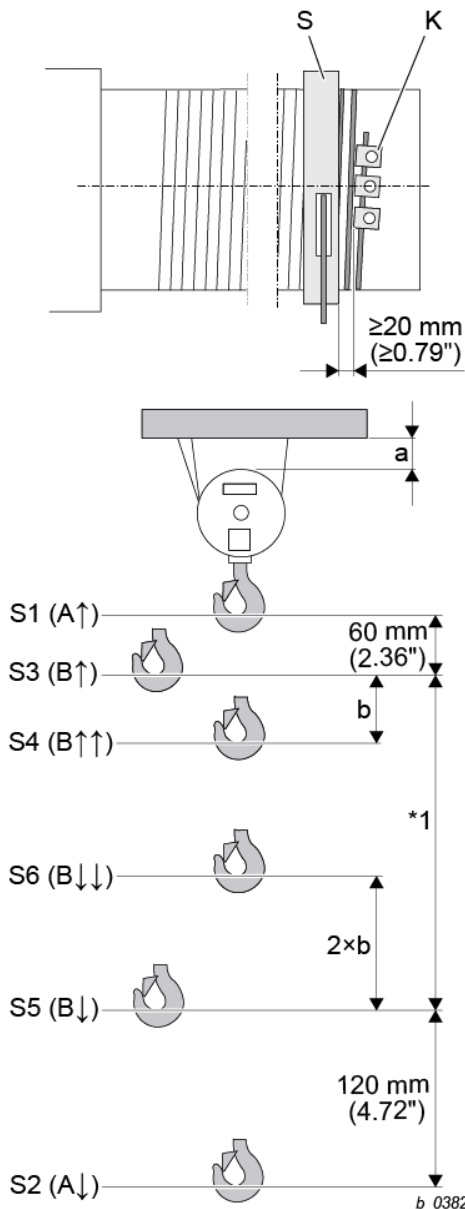

Fig. 82  
\*1 Effective hook path

### Switching point B↓/B↓↓ (S5/S6) (version 2 only) (Minimum clearance between B↓ and A↓ 4.7 in.)

1. Lower bottom hook block to **0.39 in.** above desired hook position, if necessary turn setscrew (S5) to the left beforehand. Observe minimum clearance, see Fig. 82.
2. Turn setscrew (S5) to the right until contact S5 switches audibly.
3. Lift and lower bottom hook block until B↓ (S5) is activated.

The following steps apply only for option operational hoist limit switch with pre-switching for bottom hook position!

#### Type YK/SK:

1. Lift bottom hook block by **2xb**, see Fig. 82, Tab. 35+Tab. 36.

#### Type YK/SK with VFD:

1. Use formula to calculate clearance **2xb** between (B↓↓) and (B↓).  
The factory setting of the brake ramp (t) is 1.5 s.  
The switching point (B↓↓) is dependent on drum speed (V) and brake ramp (t).  
If brake ramp (t) is altered, clearance "b" must be recalculated and reset.  
Lift bottom hook block by **2xb**.
2. Turn setscrew S6 to the right until contact S6 switches audibly.
3. Check cut-off point at fast and slow speed.
4. Ensure that hoist switches over to slow speed before cut-off point (B↓) is reached.

**⚠ WARNING Safety hazard.** Incorrectly set hoist limit switches may cause serious accidents. Check operational hoist limit switch for function and correct setting every day.

### 7.10.7 Servicing hoist limit switch

Maintenance work is restricted to checking the cut-off points. No maintenance or inspection is necessary for the hoist limit switch itself.

#### **NOTICE**

**Material damage hazard.** Any dust deposits that may be visible when the housing is opened must on no account be removed with compressed air as this would force the dust into the contacts and impair the switching function.

On no account use benzene or other solvents to clean the hoist limit switch!

---

## 7.11 Hook dimensions C for KE-S.. trolleys

The following hook dimensions C apply for the top operational hoist limit switch cut-off point (B↑).

**⚠ WARNING**

Hook dimension C must not be less than specified in the following. If the calculated flange width is between two values in the table, always set the larger dimension C.

**⚠ DANGER**

**Safety hazard.** Incorrectly set hoist limit switches may cause serious accidents.

➤ Check operational hoist limit switch for function and correct setting every day.

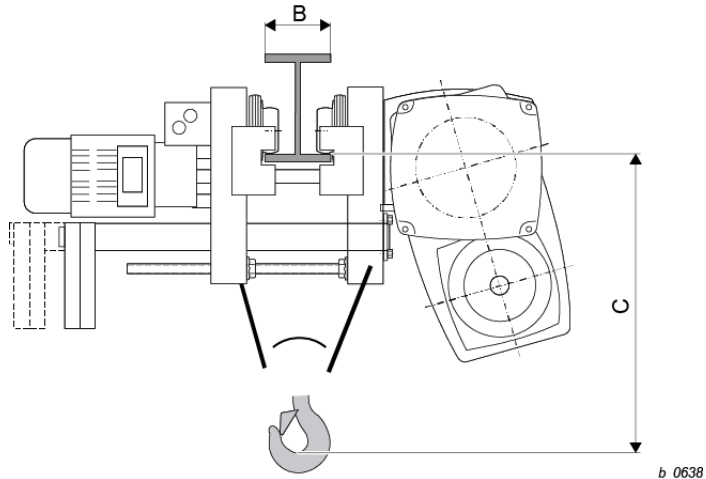

Fig. 83

Wire rope hoist	Reeving	Length	Flange width					
			4.7	6.7	11.8	15.7	19.7	
[in]								
YKA/SKA	2PS	-L2	19.3	18.5	21.3	24.2	27.2	
	4PS	-L3	16.5	15.9	18.9	21.9	24.6	
	2PD		15.4	14.8	18.5	21.3	24.2	
YKB/SKB	2PS	-L2	25	24.4	22.8	25.6	28.3	
	4PS	-L3	20.7	20.5	19.3	24	29.1	
	2PD		21.3	22.8	28.9	33.7	38.4	
YKC/SKC	Drum tensile force ≤ 2500 daN	2PS	-L2	26.2	26.2	26.2	26.6	29.3
		4PS	-L3	24.2	23.6	21.9	23.2	25.8
		2PD		20.1	19.3	19.7	22.6	25.4
		2PS	-L4	38.4	36.4	36.4	38.2	42.9
		4PS		24.2	23.6	21.9	23.2	25.8
		2PD		20.1	19.3	19.7	22.6	25.4
	Drum tensile force > 2500 daN	2PS	-L2	28	27.6	31.1	35.2	39.4
		4PS	-L3	25.4	24.8	29.1	33.5	37.8
		2PD		20.3	22.4	28	32.1	36.2
YKE/SKE	2PS	-L2	-	31.7	37.8	42.5	50	
	4PS		-	29.3	30.1	35	39.8	
	2PS	-L3	-	47.6	45.7	45.7	50	
	4PS	-L4	-	29.3	27.8	28.7	31.7	
	2PS	-L2	-	40.2	38.6	36.6	36.6	
	2PD	-L3	-	33.1	31.3	29.7	29.9	
	4PS	-L2	55.9					
		-L3						
		-L4						
		-L5						

Tab. 37

### 7.12 Overload safety device

#### 7.12.1 Testing overload safety device

If an overload is detected, the wire rope hoist is switched off in the upwards direction. Only lowering is then possible. Lifting is not possible until the wire rope hoist has been unloaded.

1. Attach a test load of 100% maximum working load + 10% overload and take load up slowly. After the rope is tautened the overload safety device must disconnect the hoist. If the hoist is not disconnected, see original operating instructions of overload device.

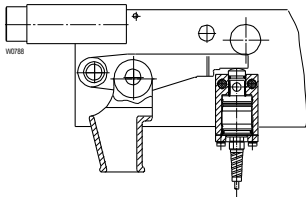

Fig. 84

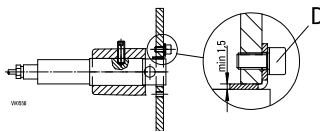
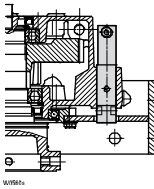

Fig. 85

#### 7.12.2 Maintenance of overload safety device with pressure sensor

1. After off-loading hoist, check all moving parts for ease of movement.
2. Clean without dismantling and grease from the outside with a thin-bodied lubricant.

#### 7.12.3 Maintenance of overload safety device with shear force sensor

1. Check plate thickness (min. 0.059 in.)
2. If necessary, replace plate after removing screw (D).

### 7.13 Crane test

#### ⚠ WARNING

**Safety hazard.** Make sure that the crane test is performed by a qualified person.

Test loads must be provided by the owner.

The crane test is part of commissioning the wire rope hoist. The test comprises:

#### **Dynamic test: 1.1 × maximum working load**

Test each direction of movement at slow and fast speed. The crane must operate smoothly during the test.

#### **Static test: 1.25 × maximum working load**

The test load must not be lifted more than max. 7.9 in from the ground at slow speed during the static test.



To enable this test to be performed, a qualified person can raise the overload cut-off threshold following the original operating instructions of the overload device.

### 7.14 Rope drive

#### 7.14.1 Rope and rope attachment - general information

After commissioning a new wire rope hoist, or after replacing the rope, the rope of multi-fall hoists may twist.

This can be seen from the bottom hook block turning, particularly when unloaded.

#### ⚠ WARNING

**Damaged or twisted rope hazard.** Twisting in the rope prejudices safety and service life.

- Remove any twists!

#### ⚠ WARNING

**Wire fracture hazard.** In certain applications (e.g. twist-free wire rope, constant deadweight, recurrent stopping position, automatic operation, vibrations etc.) wire fractures may occur inside the rope without being visible from outside.

Risk of accident!

- In case of doubt please contact the manufacturer.

1. Regularly inspect the rope for twisting. To do so, run the hoist into highest and lowest hook positions without load.
2. If any twisting is detected, untwist the rope immediately (see page 48, section 4.11 "**Reeving rope**" and page 80, "**Removing rope**").
3. Check rope. Take particular note of the sections of rope near rope pulleys, return pulleys or equalizing pulleys and in the region of the rope anchorage.
4. If any of the following damage should occur, replace the rope immediately.
  - Excess visible wire fractures, see page 79, section 7.14.2. "**Replacement of wire rope due to broken wires**".
  - The rope must be free of load for testing to facilitate detecting any broken wires when bending the rope by hand (approximately by radius of rope sheave).
  - Nest of wire fractures or broken strand.
  - In case of equal diameter reduction of 5% along the rope
  - In case of a local diameter reduction, e.g. if a rope core fails
  - Formation of baskets or loops, knots, kinks, kink or other mechanical damage.
  - Corkscrew-type deformation. Divergence due to deformation:  $\geq 1/10 \times$  rope diameter.
  - In case of a projecting core or strands
  - In case the rope diameter is increased  $\geq 5\%$
  - In case of external corrosion like severely worn wire surfaces, slack wires
  - In case of internal corrosion, e.g. corrosion particles released from the valleys between external strands
  - In case of damage due to heat effects or an arc with corresponding external heat discoloration on the wires or clear loss of lubricants
  - In addition, the rope must be replaced as required by ISO 4309. In case of wire breakage in the strand valleys of 2 or more on  $6 \times d$ , set down the wire rope (danger of internal wire breaks)

## 7.14.2 Replacement of wire rope due to broken wires

- Part number of rope see factory certificate.
- Number of permissible broken wires see rope certificate.

YKA/SKA –  
YKC/SKC

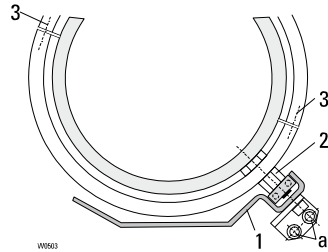

Fig. 86

## 7.14.3 Removing rope guide

First method (preferable!)

1. Unscrew protective plate (1) under the rope drum at points (a). The rope guide can then be rotated freely. Do not unscrew stop with bearing (2)!
2. Unscrew screws (3).
3. Unscrew rope guide safety cable (4) (if any) on one side.
4. Remove half-rings.
5. Unhook rope tensioning spring.

Second method

1. Unscrew stop with bearing (2) from rope guide. The rope guide can then be rotated freely. Continue as described under 1.

YKE/SKE

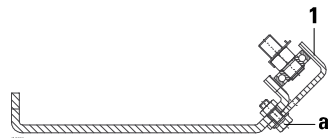

Fig. 87

YKE/SKE (2PS)

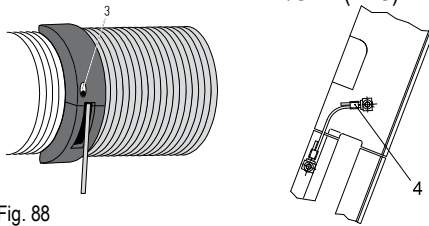

Fig. 88

### NOTICE

#### Material damage hazard

The stop with bearing (2) is locked with a conical spring washer DIN 6796. Refit the spring washer correctly.

## 7.14.4 Replacing wire rope

YK/SK wire rope hoists have a special rope which is the optimum for the most common applications.

### ⚠ WARNING

#### Hazard from unsuitable rope

The substitute rope must be equivalent to the original in terms of quality, strength and make-up. Please consult the works certificate or the rope certificate to see which rope is fitted.

- Always insert the rope correctly into the rope anchorage and secure. Replace split pin every time it is dismantled

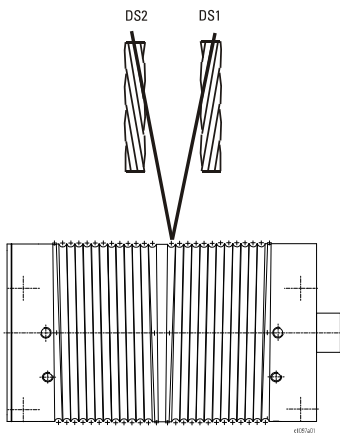

Fig. 89

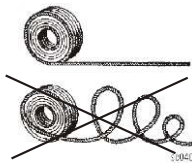

Fig. 90

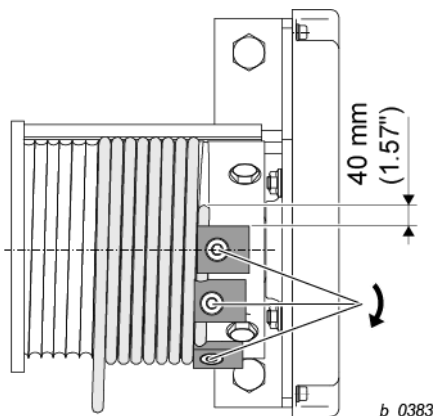

Fig. 91

#### Removing wire rope

1. Lower bottom hook block to just above the lowest hook position and set it down on a firm support.
2. Release end of wire rope in rope anchorage (rope clamp with rope wedge).
3. Run the remaining rope off the drum.
4. Unscrew the fixing screws in the clamping plates on the rope drum.

#### Fitting rope

1. Unroll new rope out straight if possible, without twists, kinks or loops. Protect rope from dirt.
2. Attach rope to rope drum with all the clamping plates (do not forget the lock washers!). Allow the rope end to project by approx. 1.2-1.6 in.
3. Tightly wind about 5-10 turns onto the drum under power. Let the rope run through a greased rag. For type of grease see page 101.
4. Fit rope guide (see page 81, section 7.14.5 "Fitting rope guide").
5. Reeve the loose end of the rope according to the number of falls, fasten with the rope wedge and secure with a rope clamp, see section "Rope anchorage".
6. Retighten clamping plates with the specified tightening torques (see following table):

Type	Metric size	Tightening torque
		[lbf ft]
YKA/SKA	M6	7.4
	M10	29.5
YKB/SKB	M10	37
YKC/SKC	M10	37
	M12	64
YKE/SKE	M12	64
	M16	155

Tab. 38

7. Run rope in with partial load.
8. **⚠ WARNING Safety hazard.** After fitting a new rope, or shortening the old one, reset the hoist limit switch. See page 72, "Setting emergency hoist limit switch".
9. Retract rope with partial load (see page 48, section 4.11 "Reeving rope").
10. If the new rope twists after some time in operation, untwist the rope immediately (see page 48, section 4.11 "Reeving rope" and page 80, "Removing rope").



## 7.14.5 Fitting rope guide

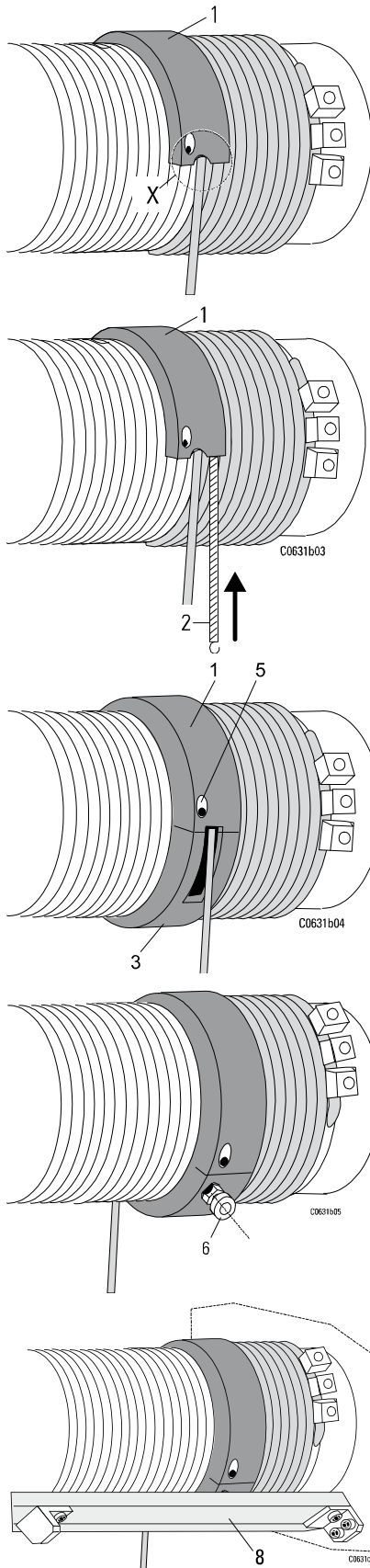
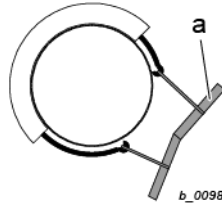

Fig. 92

1. Grease thread and rope guide groove thoroughly.
2. Place the half-ring (1) with the short window section onto the rope drum next to the last rope winding so that the rope exits from the region of the window (x).



(a) Special tool

3. With the special tool (a), push rope tensioning spring (2) into the guide groove of the half-ring (1) and hook the ends of the spring together.
4. Place the second half-ring (3) with the long rope exit window on the rope drum so that the rope exits from the drum groove through the window straight and without kinking. The second half-ring must lie flush against the first.
5. Bolt the two half-rings together with pressure screws and bolts (5)
6. The rope guide must rest lightly on the drum and must be able to be turned by hand. If this is not the case the guide has been fitted incorrectly or the rope drum is damaged.
7. Bolt stop with bearing and conical spring washer (6) to the rope guide with the specified tightening torque (see following table).

Type	Size	Tightening torque lb <sub>f</sub> ft
YKA/SKA, YKB/SKB	M8×1	15
YKC/SKC	M10×1	30
YKD/SKD, YKE/SKE	M16×1	118

### Type YKE/SKE - 2PS L4-L5

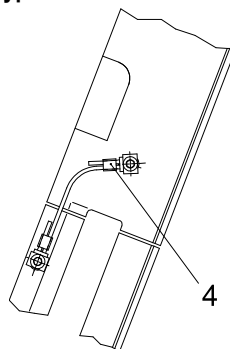

Fig. 93

1. Fit rope guide safety cable (4).
2. Bolt on protective plate (8).

## 7.14.6 Checking rope drum for wear

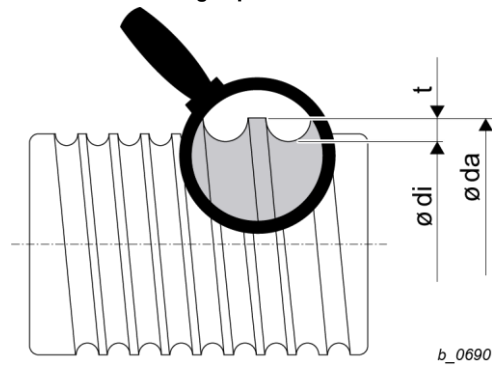

Fig. 94

b\_0690

Type of wire rope hoist	Rope diameter [in]	Nominal values			Limits for wear		
		da [in]	di [in]	t [in]	da min [in]	di min [in]	t max [in]
YKA/SKE	0.22	4.91	4.73	0.087	4.88	4.71	0.098
	0.24	4.91	4.72	0.094	4.88	4.69	0.106
	0.26 - 0.28	4.91	4.69	0.11	4.88	4.65	0.126
YKB/SKB	0.28	6.51	6.29	0.11	6.48	6.26	0.126
	0.33 - 0.35	6.51	6.22	0.144	6.48	6.19	0.161
YKC/SKC	0.33 - 0.35	8.52	8.24	0.144	8.49	8.2	0.161
	0.39	8.54	8.23	0.157	8.5	8.19	0.177
	0.47 - 0.49	8.52	8.13	0.197	8.48	8.08	0.22
YKE/SKE	0.47 - 0.49	13.86	13.46	0.197	13.81	13.42	0.22
	0.55	13.86	13.43	0.217	13.8	13.37	0.244
	0.63	13.86	13.39	0.236	13.79	13.33	0.264
	0.79	13.86	13.23	0.315	13.78	13.15	0.354

Tab. 39

## 7.14.7 Inspection and maintenance of rope sheave

1. Check rope sheaves for wear.

We recommend having them checked by a qualified person. They should also be checked for easy running, indicating that the ball bearings are in good condition.

### Wear on rope sheave

Notes on limits for wear

#### Rope sheave

Part no.	Ø D	t min	h max	h new
01 430 01 53 0	3.86	0.157	0.51	0.43
01 430 04 53 0	3.94	0.157	0.51	0.39
01 430 00 53 0	4.92	0.157	0.55	0.47
22 330 00 53 0	5.51	0.157	0.63	0.55
01 430 06 53 0	6.06	0.157	0.85	0.77
03 330 20 53 0	6.30	0.157	0.75	0.65
24 330 00 53 0	7.87	0.217	0.94	0.83
01 430 05 53 0	8.58	0.217	1.04	0.96
01 430 03 53 0	8.86	0.217	0.94	0.83
03 330 40 53 0	9.84	0.217	1.1	0.98
25 330 00 53 0	14.76	0.256	1.48	1.34
25 330 03 53 0	14.76	0.256	1.42	1.28
46 330 00 53 0	15.75	0.276	1.32	1.18
26 330 01 53 0	17.72	0.394	1.54	1.38
09 430 00 53 0	17.72	0.394	1.54	1.38
46 330 01 53 0	18.9	0.394	1.44	1.28

Tab. 40

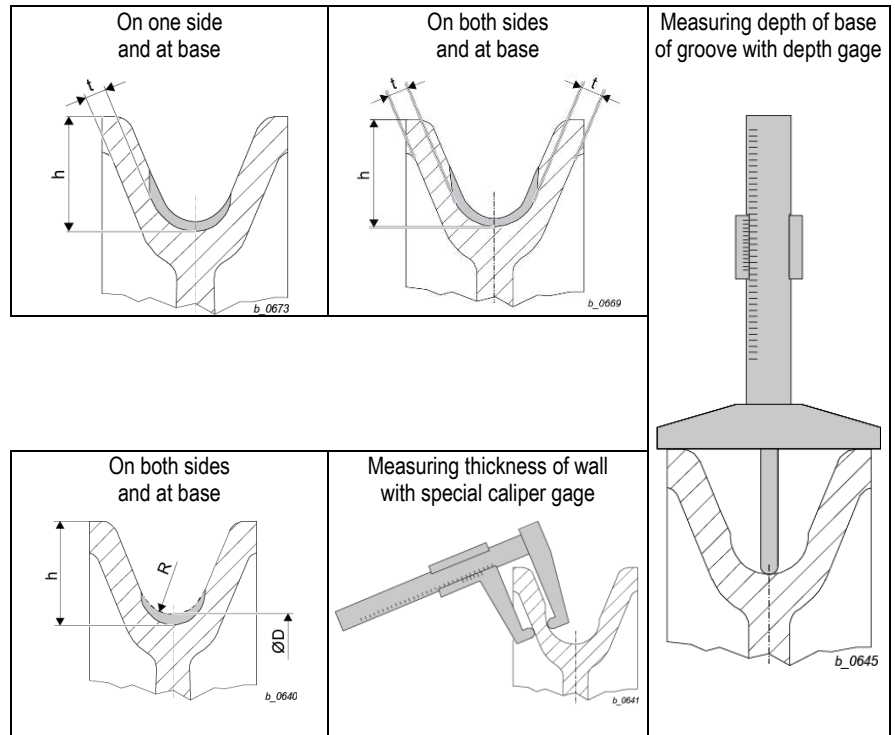

Fig. 95

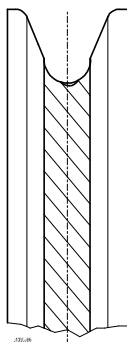

Fig. 96

The rope sheave must be replaced if the wall thickness as measured is  $< t_{\min}$  or the groove depth as measured is  $> h_{\max}$ . Furthermore, the rope sheave must be replaced when replacing the wire rope if the rope strands have dug into the base of the groove. Impressions of single wires are acceptable.

A rope sheave must also be replaced if the radius of the base of the groove  $R$  has become too small for the new rope due to reduction in diameter of the old rope or wear.



The negative profile of the rope in the base of the groove may provide optimum contact to the wire rope currently fitted.

Rope sheaves should be rotated without load on the rope to check the easy and concentric running of the bearings.

### Bottom hook blocks

#### NOTICE

**Danger of material damage.** The bottom hook block must be checked for damage. Deformations, cracks and cuts caused by impact must be assessed. The damage can only be assessed by a qualified person.

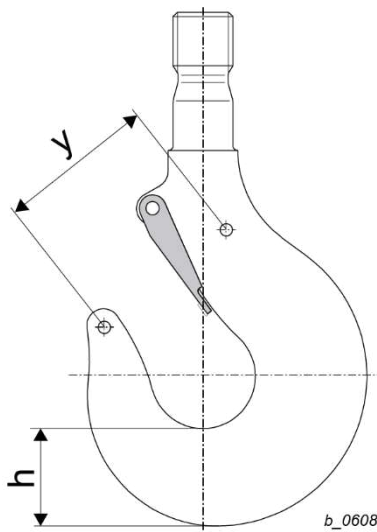

Fig. 97

### 7.14.8 Checking load hook

RSN, RS	Hook size										
	025	04	05	08	1	1.6	2.5	4	5	6	10
	[in]										
h	0.94	1.14	1.22	1.46	1.57	1.89	2.28	2.64	2.95	3.35	4.17
h min	0.9	1.09	1.16	1.39	1.5	1.8	2.17	2.51	2.81	3.18	3.96

Tab. 41

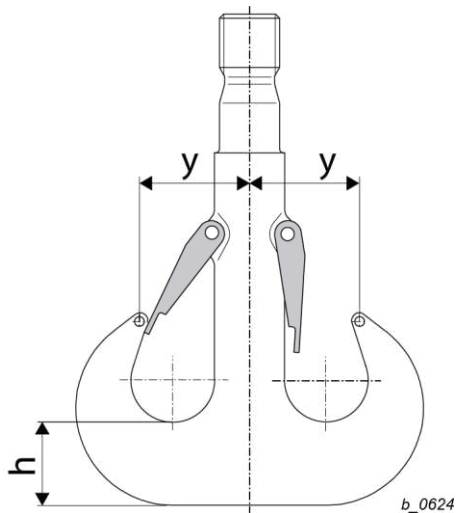

Fig. 98

RSN, RS	Hook size				
	2.5	4	5	6	10
	[in]				
h	1.97	2.36	2.64	2.95	3.74
h min	1.87	2.24	2.51	2.81	3.56

Tab. 42

$y_{new}$  see hook certificate

$y_{perm} \leq 1.1 \times y_{new}$

1. If value  $h_{min}$  and/or  $y_{perm}$  are reached, replace hook.

## 7.15 Trolley

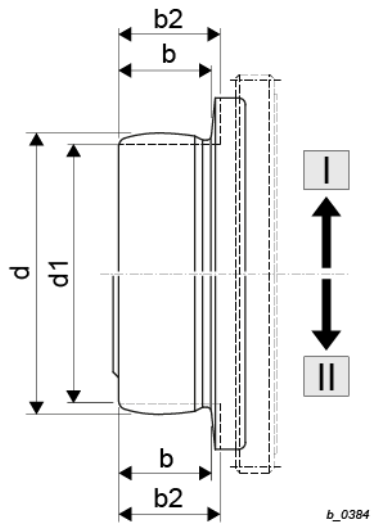

Fig. 99

b\_0384

### Wheels, wheel drive and runway

Fig.	Nominal value		Limit for wear	
	Ø d	b	Ø d1	b2
	[in]			
I	3.15	1.08	2.99	1.16
I	3.94	1.3	3.74	1.38
I	5.51	1.75	5.24	1.85
II		1.67		1.77
I	6.3	1.75	5.98	1.85
II	7.87	1.67	7.48	1.77

Tab. 43

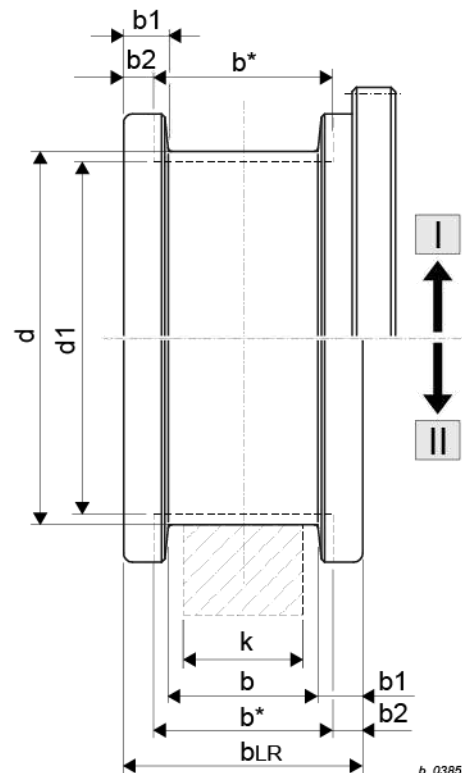

Fig. 100

b\_0385

Fig.	Ø d	Nominal value				Limit for wear		
		b <sub>LR</sub>	b	k	b1	Ø d1	b2	max play = (b*-k)
		[in]						
I	3.94	3.15	1.97	1.57	0.59	3.74	0.22	0.51
		3.15	2.36	1.97	0.39			
II	4.92	3.15	1.97	1.57	0.59	4.68	0.28	0.51
		3.15	2.36	1.97	0.39			
II	6.3	3.35	2.05	1.57	0.65	5.98	0.31	0.63
		3.35	2.44	1.97	0.45			
II	7.87	3.94	2.13	1.57	0.91	7.48	0.41	0.71
		3.94	2.13	1.77	0.91			
		3.94	2.52	1.97	0.71			
		3.94	2.52	2.17	0.71			
		3.94	2.91	2.36	0.51			
		3.94	2.91	2.56	0.51			

Tab. 44

1. Perform visual inspection of runway girder for wear.
2. Perform visual inspection of wheel flanges for wear.
3. Perform visual inspection of wheels for wear.
4. **WARNING** Safety risk. If any one of the limits for wear d1, b2, (b\*-k) is attained, the part must be replaced by a qualified person.

## 7.16 Remaining service life

The operating mode and operating time must be established by the owner, see section 1.3 and recorded in the logbook in order to calculate the remaining service life. After the service life has expired a general overhaul (S.W.P. = Safe Working Period) must be carried out.

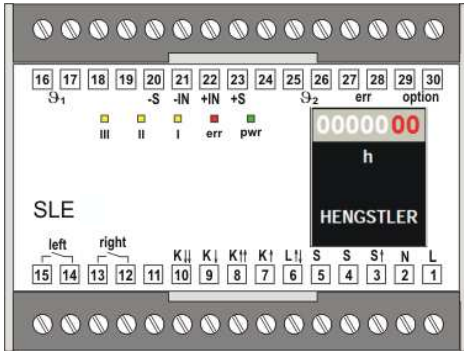

Fig. 101

### 7.16.1 Operating hours counter in SLE load monitor

The operating hours counter in the load monitor of the overload safety device adds up the operating time of the hoist. In order to obtain the lifetime expired in full load hours, the operating hours must be calculated with load factor "k". This is carried out by a qualified person during the annual "periodic inspection". If 90% of the theoretical full load lifetime has expired, a general overhaul (GO) must be scheduled and carried out at the earliest possible date.



A general overhaul must be completed after 10 years at the latest.

### 7.16.2 SMC multi-controller (optional)

The operating time of the hoist and the full load operating hours are recorded in the SMC. The SMC calculates the full load operating hours from the relevant hoisted load and the operating hours of the hoist. The remaining service life is calculated with reference to the mechanism group and can be read off by means of a PC (laptop). If the theoretical full load lifetime has expired, also indicated by an illuminated red LED, a general overhaul must be scheduled and carried out.



Reading the full load operating hours does not replace the prescribed tests including inspecting the wearing parts (rope, return sheaves...).

## 7.17 General overhaul

ISO	M4	M5	M6	M7
D [h]	800	1600	3200	6400

Tab. 45

The mechanism (motor and gear; not applicable to wearing parts) of the YK/SK wire rope hoist is classified according to ISO. The theoretical full load lifetime in hours shown opposite (D) is applicable for normal hoist applications.

If the full load lifetime (D) minus the lifetime expired is nought, the wire rope hoist must be overhauled by the manufacturer.

### NOTICE

**Danger of material damage.** Components which are in the power flux may only be overhauled by the manufacturer.

The rope drive is classified according to FEM 9.661, see factory certificate.

As the service life of components such as gears is limited in accordance with the classification, it must be ensured that this is not exceeded. After the scheduled service life has expired hazards may arise. Thus the operator must take the responsibility for the remaining service life and the necessity of a general overhaul.

We cannot accept any liability for damage occasioned by non-observance.

## 8 Wearing parts

### 8 Wearing parts

#### ⚠ WARNING

#### Safety hazard.

- Make sure that replacement and repairs are performed by qualified persons only.

#### 8.1 Serial number

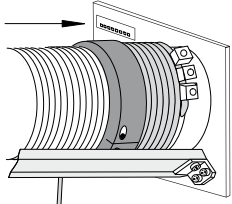

Fig. 102

When ordering original spare parts, always indicate the serial number of the hoist. This is affixed to the inside of the bearing support plate.

#### 8.2 Hoist

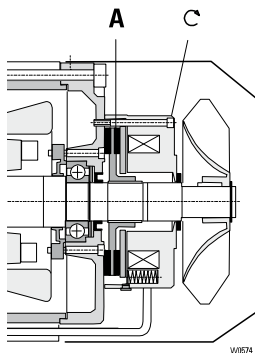

Fig. 103

#### RSM brake rotor

Hoist motor	Hoist motor brake	A	Tightening torque
		Order no.	[lbf ft]
12/2H73	RSM150	A0443067650	16
24/4H92	RSM500	A0543010650	33

Tab. 46

#### NM brake rotor

Hoist motor	Hoist motor brake	A	Tightening torque
		Order no.	[lbf ft]
12/2H33-MF..	NM 38722	A5674770	7
4H33-MF..	NM 38720	A5674770	
12/2H42-MF..	NM 38732	A5674750	7
4H42-MF..	NM 38730	A5674750	
4HS3	NM 38730	A5676320	
4HA3	NM38730	A5674780	
12/2H62-MF..	NM 38732	A5678050	16
4H62-MF..	NM 38740	A5674790	
12/2H71-MF..	NM 38742	A5674790	16
4H71-MF..	NM 38740	A5674790	
4HS5	NM 40940	A5676330	
4HA5	NM40940	A5676490	
12/2H72-MF..	NM 38754	A5675700	16
4H72-MF..	NM 38741	A5675690	
4HS7	NM 40951	A5676340	
4H73-MF..	NM 38753	A5675500	16
4SH8	NM 40980	A5676350	
4H81-MF	NM 38753	A5675500	16
4H82-MF..	NM 38781	A5675710	16
4HSA	NM 40980	A5676350	
12/2H91	NM 38790	A5675910	33

Tab. 47

## 8 Wearing parts

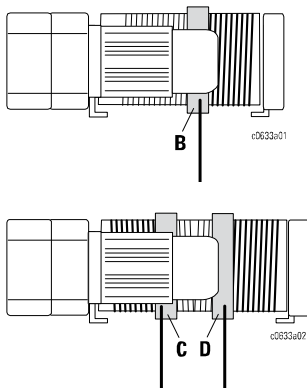

Fig. 104

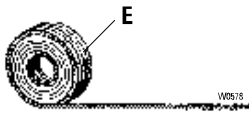

Fig. 105

### Rope guide

Wire rope hoist type	B	C	D
	Order no.	Order no.	Order no.
YKA/SKA	A0343002430	A0343001430	A0343000430
YKB/SKB	A0443000430	A0443002430	A0443001430
YKC/SKC	A0543001430	A0543002430	A0543000430
YKE/SKE (2PS), L4 - L5	A0643008430	-	-
YKE/SKE	A0643003430	A0643004430	A0643000430

Tab. 48

### Wire rope (E)

See factory certificate or rope certificate for length and number of wire rope.



## 9 Troubleshooting

### 9 Troubleshooting

**⚠ DANGER**



**Electric shock hazard.**

- Make sure an electrical qualified person performs the work.
- Disconnect power and implement a Lockout/Tagout (LOTO) procedure before servicing the equipment.

Trouble	Possible cause	Remedy
<b>Hoist does NOT operate</b>	No power to hoist	<ol style="list-style-type: none"> <li>1. Check switches, and fuses.</li> <li>2. Check connections in power supply lines.</li> <li>3. Check power collectors.</li> </ol>
	Wrong voltage	<ol style="list-style-type: none"> <li>1. Check if the supply voltage is in accordance with the voltage indicated on motor data plate.</li> </ol>
	Loose or broken wire connections	<ol style="list-style-type: none"> <li>1. Shut off the power.</li> <li>2. Remove electrical cover, and check wire connections.</li> <li>3. Check wire connections of control pendant.</li> <li>4. Check wire connections of limit switches.</li> <li>5. Correct wiring if necessary.</li> </ol>
	Contactors not functioning	<ol style="list-style-type: none"> <li>1. Check if jumper wires are properly installed.</li> <li>2. Check if contactor armatures move freely.</li> <li>3. Check if contactor is burned or welded.</li> <li>4. Replace contactor if necessary.</li> </ol>
	No control voltage	<ol style="list-style-type: none"> <li>1. Check if transformer fuse is blown.</li> <li>2. If fuse is burn, check control pendant for grounding and/or shorts.</li> <li>3. Check transformer coil for signs of overheating.</li> <li>4. Check if the transformer secondary is the same voltage as the coils to which it is connected.</li> <li>5. Replace transformer if necessary.</li> </ol>
	Motor burned out	<ol style="list-style-type: none"> <li>1. Replace motor.</li> <li>2. Check input power supply.</li> <li>3. Check hoist motor connections.</li> </ol>
<b>Hoist does NOT operate, motor hums</b>	Not all power phases are present	<ol style="list-style-type: none"> <li>1. Check fuses, replace if necessary</li> <li>2. Check input power supply.</li> <li>3. Check control pendant.</li> </ol>
<b>Hoist does NOT start after a longer shutdown, or starts with difficulty, motor hums.</b>	Hoist brake stuck	<ol style="list-style-type: none"> <li>1. Check brake.</li> <li>2. Replace brake if necessary.</li> </ol>
<b>Hoist motor overheats</b>	Excessive load	<ol style="list-style-type: none"> <li>1. Reduce load to rated load of hoist, as shown on nameplate.</li> </ol>
	Excessive duty cycle	<ol style="list-style-type: none"> <li>1. Reduce frequency of lifts.</li> <li>2. Reduce amount of jogging.</li> </ol>
	Wrong voltage or frequency	<ol style="list-style-type: none"> <li>1. Check if the supply voltage is in accordance with the voltage indicated on motor data plate.</li> <li>2. Check hoist and inspect for defective, worn or damaged parts.</li> </ol>
	Defective motor or worn bearings in hoist frame	<ol style="list-style-type: none"> <li>1. Disassemble hoist.</li> <li>2. Inspect for defective, worn or damaged parts.</li> <li>3. Replace parts if necessary.</li> </ol>
<b>Hoist operates intermittently</b>	Collectors make poor contact	<ol style="list-style-type: none"> <li>1. Check electrical connections.</li> <li>2. Check collectors for free movement of spring arms, or weak springs.</li> </ol>
	Loose contacts	<ol style="list-style-type: none"> <li>1. Check wire connections.</li> <li>2. Correct wiring if necessary.</li> </ol>
<b>Braking distance is too long</b>	Brake lining worn	<ol style="list-style-type: none"> <li>1. Replace brake disk.</li> </ol>

## 9 Troubleshooting

Trouble	Possible cause	Remedy
Loud clicking noise when motor starts	Air gap on brake is too wide	<ol style="list-style-type: none"> <li>1. Measure air gap on motor.</li> <li>2. Replace brake disk if the maximum air gap is reached.</li> </ol>
Lifting of rated load NOT possible	Low voltage	<ol style="list-style-type: none"> <li>1. Check if the supply voltage is in accordance with the voltage indicated on motor data plate.</li> <li>2. Check hoist motor connections.</li> <li>3. Check size of power supply lines.</li> </ol>
Hook moves in wrong direction	Hoist wired incorrectly	<ol style="list-style-type: none"> <li>1. Check wiring connections with appropriate wiring diagram.</li> <li>2. Correct wiring if necessary.</li> </ol>
Lifting NOT possible	Upper hook position is reached	<ol style="list-style-type: none"> <li>1. Activate DOWN button</li> </ol>
	Excessive load	<ol style="list-style-type: none"> <li>2. Reduce load to rated load of hoist, as shown on nameplate</li> </ol>
	Limit switch defective	<ol style="list-style-type: none"> <li>1. Check operational hoist limit switch.</li> <li>2. Check emergency hoist limit switch.</li> <li>3. Replace limit switch if necessary.</li> </ol>
	Condition monitoring device (SMC..., SLE..) is activated or is defective	<ol style="list-style-type: none"> <li>1. Check supplied manual of the condition monitoring device (SMC..., SLE..)</li> </ol>
	UP button inoperative	<ol style="list-style-type: none"> <li>1. Check button contacts and wires.</li> <li>2. Correct wiring or repair control pendant if necessary.</li> </ol>
	Contact assembly not functioning	<ol style="list-style-type: none"> <li>1. Check if jumper wires are properly installed.</li> <li>2. Check if contactor armatures move freely.</li> <li>3. Check if contactor is burned or welded.</li> <li>4. Correct wiring or replace contactor if necessary.</li> </ol>
	Hoist electrical circuit open	<ol style="list-style-type: none"> <li>1. Check if connections are loose.</li> <li>2. Check if jumper wires on contactor are properly installed.</li> <li>3. Correct wiring if necessary.</li> </ol>
Lowering NOT possible	Bottom hook position is reached	<ol style="list-style-type: none"> <li>1. Activate UP button</li> </ol>
	Limit switch faulty	<ol style="list-style-type: none"> <li>1. Check operational hoist limit switch.</li> <li>2. Check emergency hoist limit switch.</li> <li>3. Replace limit switch if necessary.</li> </ol>
	DOWN button inoperative	<ol style="list-style-type: none"> <li>1. Check button contacts and wires.</li> <li>2. Correct wiring or repair control pendant if necessary.</li> </ol>
	Contact assembly not functioning	<ol style="list-style-type: none"> <li>1. Check if jumper wires are properly installed.</li> <li>2. Check if contactor armatures move freely.</li> <li>3. Check if contactor is burned or welded.</li> <li>4. Correct wiring or replace contactor if necessary.</li> </ol>
	Lower electrical circuit open	<ol style="list-style-type: none"> <li>1. Check if connections are loose.</li> <li>2. Check if jumper wires on contactor are properly installed.</li> <li>3. Correct wiring if necessary.</li> </ol>
Hook block and rope are rotating	Rope twisted	<ol style="list-style-type: none"> <li>1. Turn rope anchorage 1 to 2 times in opposite direction (360°) to the twisted rope.</li> <li>2. Perform several runs without load over the full lifting height.</li> <li>3. If necessary, repeat these steps 2 times.</li> </ol>
Hoist does NOT follow the control commands	Condition monitoring device error	<ol style="list-style-type: none"> <li>1. Check supplied manual of the condition monitoring device (SMC..., SLE..)</li> </ol>
Cross traveling NOT possible	Excessive load	<ol style="list-style-type: none"> <li>1. Reduce load to rated load of hoist, as shown on nameplate.</li> </ol>
	Travel limit switch defective	<ol style="list-style-type: none"> <li>1. Check travel limit switch, replace if necessary</li> </ol>
	Fuses defective	<ol style="list-style-type: none"> <li>1. Check fuses, replace if necessary</li> </ol>
Load drifts excessively when hoist is stopped	Excessive load	<ol style="list-style-type: none"> <li>1. Reduce load to rated load of hoist, as shown on nameplate.</li> </ol>

## 10 Decommissioning

---

### 10 Decommissioning

#### 10.1 Dismantling

#### ▲ WARNING

##### Falling parts hazard

➤ Secure hoist when dismantling.

---

1. Dismantle hoist correctly.
2. First remove lubricants.

#### 10.2 Scrap disposal

#### NOTICE

Electronic components, electric scrap, lubricants and other auxiliary substances are hazardous waste and may only be disposed of by approved recycling companies. Overload devices must be returned to the manufacturer.

---

Dismantled components must be recycled after correct dismantling. It is imperative to observe national regulations on environmentally compatible disposal. Local authorities will provide relevant information.

## 11 Technical data

---

### 11 Technical data

#### 11.1 Conditions of use

The hoist is designed for use in industry and for the ambient conditions usual in industry in non-hazardous areas.

Special measures are necessary for particular applications such as e.g. high degree of chemical pollution, outdoor use, offshore application, etc.

The manufacturer will be pleased to advise you.

#### **Protection against dust and moisture to EN 60529**

See factory certificate

#### **Permissible ambient temperatures**

See factory certificate

# 11 Technical data

## 11.2 Hoist

The designation of the type of wire rope hoist and the motor installed can be seen from the rating plate/factory certificate.

All technical data given refer to the standard version and standard operating conditions. The technical data given in the order acknowledgement or individual documentation apply for optional versions and off-standard applications. Motor specifications for more information and further technical details are available on request.

### 11.2.1 Pole-changing hoist motors ...-MF 50Hz

50 Hz										
Motor *3	Power	DC	[c/h]	I <sub>N</sub>	I <sub>k</sub>	I <sub>N</sub>	I <sub>k</sub>	cos phi k	Mains fuse CC / J *2	
				220...240 V		380...415 V			220...240 V	380...415 V
	[HP]	[%]		[A]						[A]
12/2H33-MF	0.5/3.2	20/60	480/240	6.4/10.4	13.2/67.8	3.7/6.0	7.6/39.0	0.78/0.83	20	15
	0.5/3.9	20/50	360/180	6.6/12.2		3.8/7.0				
	0.7/4.8	20/40	240/120	7.1/14.0		4.1/8.2				
12/2H42-MF	0.5/3.9	20/60	480/240	8.7/12.2	15.0/76.5	5.0/7.0	8.6/44.0	0.77/0.84	20	15
	0.7/4.8	20/50	360/180	8.7/14.6		5.0/8.4				
	0.9/6	20/40	240/120	9.6/17.0		5.5/9.9				
12/2H62-MF	1.3/8	20/60	480/240	15.5/23.5	27.8/144.0	8.9/13.5	16.0/83.0	0.69/0.77	50	25
	1.6/10.1	20/50	360/180	16.0/28.0		9.0/16.0				
12/2H71-MF *1	1.3/8	20/60	480/240	15.5/23.5	27.8/144.0	8.9/13.5	16.0/83.0	0.69/0.77	50	30
	1.6/10.1	20/50	360/180	15.7/28.3		9.0/16.3				
	1.9/12.1	20/40	240/120	19.0/33.0		11.0/19.0				
12/2H72-MF *1	2.7/16.1	20/50	360/180	20.9/43.5	43.5/252.0	12.0/25.0	25.0/145.0	0.68/0.67	80	50
	3.4/20.1	20/40	240/120	24.0/56.0		14.0/32.0				
12/2H91-MF *1	6.7/40.2	20/40	240/120	45.0/101.0	78.3/435.0	26.0/58.0	45.0/250.0	0.60/0.70	100	60

50 Hz										
Motor *3	Power	DC	[c/h]	I <sub>N</sub>	I <sub>k</sub>	I <sub>N</sub>	I <sub>k</sub>	cos phi k	Mains fuse CC / J *2	
				420...460 V		500...525 V			420...460 V	500...525 V
	[HP]	[%]		[A]						[A]
12/2H33-MF	0.5/3.2	20/60	480/240	3.4/5.5	6.9/35.5	3.0/4.8	6.1/31.2	0.78/0.83	15	15
	0.5/3.9	20/50	360/180	3.5/6.4		3.0/5.6				
	0.7/4.8	20/40	240/120	3.7/7.5		3.3/6.6				
12/2H42-MF	0.5/3.9	20/60	480/240	4.5/6.4	7.8/40.0	4.0/5.6	6.9/35.2	0.77/0.84	15	15
	0.7/4.8	20/50	360/180	4.5/7.6		4.0/6.7				
	0.9/6	20/40	240/120	5.0/9.0		4.4/7.9				
12/2H62-MF	1.3/8	20/60	480/240	8.1/12.3	14.5/75.5	7.1/10.8	12.8/66.4	0.69/0.77	25	20
	1.6/10.1	20/50	360/180	8.2/14.5		7.2/13.0				
12/2H71-MF *1	1.3/8	20/60	480/240	8.1/12.3	14.5/75.5	7.1/10.8	12.8/66.4	0.69/0.77	25	25
	1.6/10.1	20/50	360/180	8.2/14.8		7.2/13.0				
	1.9/12.1	20/40	240/120	10.0/17.3		8.8/15.0				
12/2H72-MF *1	2.7/16.1	20/50	360/180	10.9/22.7	22.7/132.0	9.6/20.0	20.0/116.0	0.68/0.67	50	30
	3.4/20.1	20/40	240/120	12.7/29.0		11.0/26.0				
12/2H91-MF *1	6.7/40.2	20/40	240/120	24.0/53.0	40.9/227.0	21.0/47.0	36.0/200.0	0.60/0.70	60	50

Tab. 49

Motor currents at other voltages:

$$\text{Formula } I_{xV} = I_{400V} * \frac{400V}{xV}$$

\*1 Operation only with special starting circuit via 12-pole winding.

\*2 The 2-pole starting current for main hoist and the rated current for the travel motor were taken into consideration when selecting the main fuse.

\*3 The motors are designed for rated voltage ranges. In accordance with EN 60034 a voltage tolerance of ±5% and a frequency tolerance of ±2% apply on top of the rated voltage ranges. The maximum current occurring in the rated voltage range is given.

11.2.2 Pole-changing hoist motors ..../...-MF 60Hz

60 Hz										
Motor *3	Power	DC	[c/h]	I <sub>N</sub>	I <sub>K</sub>	I <sub>N</sub>	I <sub>K</sub>	cos phi k	Mains fuse CC / J *2	
				208...230 V		360...400 V			208...230 V	360...400 V
	[HP]	[%]	[A]				[A]			
12/2H33-MF	0.7/4.7	20/50	360/180	8.2/15.3	15.3/89.9	4.7/8.8	8.8/52.1	0.73/0.77	25	20
	0.9/5.8	20/40	240/120	8.4/17.0		4.8/10.0				
12/2H42-MF	0.9/5.8	20/50	360/180	10.2/17.8	17.6/102.0	5.9/10.3	10.2/59.3	0.74/0.78	25	20
	1.2/7.2	20/40	240/120	11.0/22.0		6.5/13.0				
12/2H62-MF	1.6/9.7	20/60	480/240	17.8/28.2	31.4/167.0	10.3/16.3	18.2/96.8	0.68/0.75	50	30
	1.9/12.1	20/50	360/180	18.0/33.0		10.5/19.0				
12/2H71-MF *1	1.6/9.7	20/60	480/240	17.8/28.2	31.4/167.0	10.3/16.3	18.2/96.8	0.68/0.75	60	30
	1.9/12.1	20/50	360/180	18.2/33.5		10.5/19.4				
	2.1/14.8	20/40	240/120	21.0/42.0		12.0/24.0				
12/2H72-MF *1	3.1/18.8	20/50	360/180	27.2/54.4	52.3/312.0	15.7/31.5	30.3/180.0	0.64/0.60	80	50
	4/24.1	20/40	240/120	27.0/67.0		16.0/39.0				
12/2H91-MF *1	8/48.3	20/40	240/120	54.4/121.0	94.1/523.0	31.5/70.0	54.5/303.0	0.60/0.70	125	60

60 Hz										
Motor *3	Power	DC	[c/h]	I <sub>N</sub>	I <sub>K</sub>	I <sub>N</sub>	I <sub>K</sub>	cos phi k	Mains fuse CC / J *2	
				440...480 V		575...600 V			440...480 V	575...600 V
	[HP]	[%]	[A]				[A]			
12/2H33-MF	0.7/4.7	20/50	360/180	3.9/7.3	7.3/43.0	3.1/5.8	5.8/34.4	0.73/0.77	15	15
	0.9/5.8	20/40	240/120	4.0/8.3		3.2/6.6				
12/2H42-MF	0.9/5.8	20/50	360/180	4.9/8.5	8.4/49.0	3.9/6.8	6.7/39.2	0.74/0.78	15	15
	1.2/7.2	20/40	240/120	5.4/10.0		4.3/8.2				
12/2H62-MF	1.6/9.7	20/60	480/240	8.5/13.5	15.0/80.0	6.8/10.8	12.0/64.0	0.68/0.75	25	20
	1.9/12.1	20/50	360/180	8.7/16.0		7.0/12.8				
12/2H71-MF *1	1.6/9.7	20/60	480/240	8.5/13.5	15.0/80.0	6.8/10.8	12.0/64.0	0.68/0.75	30	25
	1.9/12.1	20/50	360/180	8.7/16.0		7.0/12.8				
	2.1/14.8	20/40	240/120	10.0/20.0		8.0/16.0				
12/2H72-MF *1	3.1/18.8	20/50	360/180	13.0/26.0	25.0/149.0	10.4/20.8	20.0/119.0	0.64/0.60	50	30
	4/24.1	20/40	240/120	13.0/32.0		10.0/26.0				
12/2H91-MF *1	8/48.3	20/40	240/120	26.0/58.0	45.0/250.0	21.0/47.0	36.0/200.0	0.60/0.70	60	50

Tab. 50

Motor currents at other voltages:

$$\text{Formula } I_{xV} = I_{400V} * \frac{400V}{xV}$$

- \*1 Operation only with special starting circuit via 12-pole winding.
- \*2 The 2-pole starting current for main hoist and the rated current for the travel motor were taken into consideration when selecting the main fuse.
- \*3 The motors are designed for rated voltage ranges. In accordance with EN 60034 a voltage tolerance of ±5% and a frequency tolerance of ±2% apply on top of the rated voltage ranges. The maximum current occurring in the rated voltage range is given.

# 11 Technical data

## 11.2.3 Pole-changing hoist motors 50Hz

50 Hz										
Motor *3	Power	DC	[c/h]	I <sub>N</sub>	I <sub>K</sub>	I <sub>N</sub>	I <sub>K</sub>	cos phi k	Mains fuse CC / J *2	
				220...240 V		380...415 V			220...240 V	380...415 V
	[HP]	[%]		[A]					[A]	
12/2H73 *1	4.2/25.5	20/50	360/180	38.4/62.6	76.5/423	22.0/36.0	44.0/243	0.59/0.63	100	60
	5.1/32.2	20/40	240/120	38.3/83.5		22.0/48.0				
24/4H92 *1	7.5/51	13/27	160/80	-	-	53.0/73.0	76.0/471	0.51/0.63	-	100

50 Hz										
Motor *3	Power	DC	[c/h]	I <sub>N</sub>	I <sub>K</sub>	I <sub>N</sub>	I <sub>K</sub>	cos phi k	Mains fuse CC / J *2	
				480...525 V					480...525 V	
	[HP]	[%]		[A]					[A]	
12/2H73 *1	4.2/25.5	20/50	360/180	17.6/28.8	35.2/194			0.59/0.63	60	
	5.1/32.2	20/40	240/120	17.6/38.4						
24/4H92 *1	7.5/51	13/27	160/80	42.4/58.4	60.8/377			0.51/0.63	80	

Tab. 51

## 11.2.4 Pole-changing hoist motors 60Hz

60 Hz										
Motor *3	Power	DC	[c/h]	I <sub>N</sub>	I <sub>K</sub>	I <sub>N</sub>	I <sub>K</sub>	cos phi k	Mains fuse CC / J *2	
				220...240 V		380...415 V			220...240 V	380...415 V
	[HP]	[%]		[A]					[A]	
12/2H73 *1	5/30.6	20/50	360/180	44.0/72.0	88.0/486	25.3/41.4	50.6/279	0.59/0.63	125	80
	6/38.6	20/40	240/120	44.0/96.0		25.3/55.2				
24/4H92 *1	9.1/61.7	13/27	160/80	-	-	61.0/84.0	87.0/542	0.51/0.63	-	125

60 Hz										
Motor *3	Power	DC	[c/h]	I <sub>N</sub>	I <sub>K</sub>	I <sub>N</sub>	I <sub>K</sub>	cos phi k	Mains fuse CC / J *2	
				440...480 V		550...600 V			440...480 V	550...600 V
	[HP]	[%]		[A]					[A]	
12/2H73 *1	5/30.6	20/50	360/180	22.0/36.0	44.0/243	17.6/28.8	35.2/194	0.59/0.63	60	60
	6/38.6	20/40	240/120	22.0/48.0		17.6/38.4				
24/4H92 *1	9.1/61.7	13/27	160/80	53.0/73.0	76.0/471	42.0/58.0	60.8/377	0.51/0.63	100	80

Tab. 52

Motor currents at other voltages:

$$\text{Formula } I_{xV} = I_{400V} * \frac{400V}{xV}$$

\*1 Operation only with special starting circuit via 12-pole or 24-pole winding.

\*2 The 2-pole or 4-pole starting current for main hoist and the rated current for the travel motor were taken into consideration when selecting the main fuse.

\*3 The motors are designed for rated voltage ranges. In accordance with EN 60034 a voltage tolerance of ±5% and a frequency tolerance of ±2% apply on top of the rated voltage ranges. The maximum current occurring in the rated voltage range is given.

## 11.2.5 Frequency-controlled hoist motors ../4H..-MF 100 Hz

Hoist motor *3	Power	DC	100 Hz					
			I <sub>n</sub>			Mains fuse CC / J *1		
			380...415 V	500...525 V	660...690 V	380...415 V	500...525 V	660...690 V
	[HP]	[%]	[A]			[A]		
4H33-MF	3.9	70	8.3	6.6	5.0	10	10	10
	4.8	60	9.4	7.5	5.7			
4H42-MF	4.8	70	9.3	7.4	5.6	15	10	10
	6	60	10.7	8.6	6.5			
4H62-MF	8	70	15.5	12.4	9.4	20	10	10
	10.1	60	18.0	14.4	10.9			
4H71-MF	10.1	70	18.0	14.4	10.9	25	15	15
	12.1	60	21.0	17.0	12.7			
4H72-MF	16.1	70	25.0	20.0	15.2	30	20	20
	20.1	60	31.0	25.0	19.0			
4H73-MF	24.1	70	34.0	27.2	20.6	50	30	30
	30.8	60	42.0	34.0	26.0			
4H81-MF	30.8	70	45.0	36.0	27.3	60	40	40
	37.5	60	55.0	44.0	33.0			
4H82-MF	37.5	70	57.0	45.6	34.5	80	50	50
	46.9	60	64.0	51.0	39.0			

Tab. 53

## 11.2.6 Frequency-controlled hoist motors ../4H..-MF 120 Hz

Hoist motor *3	Power	DC	120 Hz					
			I <sub>n</sub>			Mains fuse CC / J *1		
			360...400 V	440...480 V	575...600 V	360...400 V	440...480 V	575...600 V
	[HP]	[%]	[A]			[A]		
4H33-MF	4.7	70	9.9	8.2	6.6	10	10	10
	5.8	60	11.3	9.3	7.4			
4H42-MF	5.8	70	11.3	9.3	7.4	15	15	10
	7.2	60	13.1	10.8	8.6			
4H62-MF	9.7	70	20.6	17.0	13.6	20	20	10
	12.1	60	23.0	19.0	15.2			
4H71-MF	12.1	70	23.0	19.0	15.2	25	25	15
	14.8	60	27.0	22.0	18.0			
4H72-MF	18.8	70	31.5	26.0	20.8	30	30	20
	24.1	60	38.0	31.0	25.0			
4H73-MF	28.2	70	43.6	36.0	28.8	50	50	30
	36.2	60	53.0	44.0	35.0			
4H81-MF	37.5	70	55.7	46.0	36.8	60	60	40
	45.6	60	68.0	56.0	45.0			
4H82-MF	45.6	70	67.8	56.0	44.8	80	80	50
	56.3	60	79.0	65.0	52.0			

Tab. 54

\*1 Protection not 100% with CC / J, we recommend additional semiconductor fuses.

\*3 The motors are designed for rated voltage ranges. In accordance with EN 60034 a voltage tolerance of  $\pm 5\%$  and a frequency tolerance of  $\pm 2\%$  apply on top of the rated voltage ranges. If these are fully utilized, the permissible limit temperature of the temperature class may be exceeded by 10 K. The maximum current occurring in the rated voltage range is given.



## 11.2.7 Frequency-controlled hoist motors ../4HS.-MF 100 Hz

Hoist motor *3	Power	DC	100 Hz					
			I <sub>n</sub>			Mains fuse CC / J *1		
			380...415 V	500...525 V		380...415 V	500...525 V	
[HP]	[%]	[A]			[A]			
4HS3	3.9	80	8.3	6.6		15	10	
	4.8	70	9.3	7.4				
	6	60	10.7	8.6				
4HS5	8	80	15.5	12.4		25	15	
	10.1	70	18.0	14.4				
	12.1	60	21.0	16.8				
4HS7	16.1	80	24.0	19.2		50	25	
	20.1	70	28.0	22.4				
	24.1	60	34.0	27.2				
4HS8	24.1	70	34.0	27.2		50	30	
	30.8	60	42.0	33.6				
4HSA	37.5	70	57.0	45.6		80	50	
	46.9	60	64.0	51.2				

Tab. 55

## 11.2.8 Frequency-controlled hoist motors ../4HS.-MF 120 Hz

Hoist motor *3	Power	DC	120 Hz					
			I <sub>n</sub>			Mains fuse CC / J *1		
			440...480 V	575...600 V		440...480 V	575...600 V	
[HP]	[%]	[A]			[A]			
4HS3	4.7	80	8.1	6.5		15	10	
	5.8	70	9.3	7.4				
	7.2	60	10.8	8.6				
4HS5	9.7	70	17.0	13.6		25	15	
	12.1	60	19.0	15.2				
	14.8	60	22.0	17.6				
4HS7	18.8	80	23.0	18.4		50	25	
	24.1	70	26.0	20.8				
	28.2	60	36.0	28.8				
4HS8	28.2	70	36.0	28.8		50	30	
	36.2	60	44.0	35.2				
4HSA	45.6	70	56.0	44.8		80	50	
	56.3	60	65.0	52.0				

Tab. 56

\*1 Protection not 100% with CC / J, we recommend additional semiconductor fuses.

\*3 The motors are designed for rated voltage ranges. In accordance with EN 60034 a voltage tolerance of  $\pm 5\%$  and a frequency tolerance of  $\pm 2\%$  apply on top of the rated voltage ranges. If these are fully utilized, the permissible limit temperature of the temperature class may be exceeded by 10 K. The maximum current occurring in the rated voltage range is given.

11.3 Cable cross sections and lengths of supply cable

11.3.1 Cable cross sections and lengths of supply cable for pole-changing hoist motors ...-MF

1 Hoist motor type	2 Stationary Hoist				3 Hoist/crane				4 Hoist				5 Rising mains max. 33 ft		6 Crane				7 Crane			
	Fixed installation in PVC conduit				Fixed installation in PVC conduit				Festoon cable in free air as flexible PVC-sheathed cable				Fixed installation in PVC conduit		Festoon cable in free air as flexible PVC-sheathed cable				Festoon cable in free air as flexible PVC-sheathed cable			
	Power supply to hoist				Power supply to in-feed (customer's cable to beginning of rising mains)				From end of rising mains to hoist				From main isolator to end of rising mains		From end of rising mains along crane runway to crane control				Power supply along crane bridge to hoist			
	$\Delta U \leq 5\%$				$\Delta U \leq 1\%$				$\Delta U \leq 4\% (4+5)$						$\Delta U \leq 1.5\% (5+6)$				$\Delta U \leq 2.5\%$			
50 Hz																						
	380-415 V		500-525 V		380-415 V		500-525 V		380-415 V		500-525 V		400 V	500 V	380-415 V		500-525 V		380-415 V		500-525 V	
	S	L1	S	L1	S	L2	S	L2	S	L3	S	L3	S	S	S	L4	S	L4	S	L5	S	L5
	AWG	[ft]	AWG	[ft]	AWG	[ft]	AWG	[ft]	AWG	[ft]	AWG	[ft]	AWG	AWG	AWG	[ft]	AWG	[ft]	AWG	[ft]	AWG	[ft]
12/2H33	12	212	14	208	10	67	12	66	12	149	14	146	10	12	8	109	10	106	12	106	14	104
12/2H42	10	288	12	283	8	92	10	90	10	210	12	206	8	10	8	104	10	102	10	144	12	141
12/2H62	8	273	10	268	6	87	8	85	8	198	10	194	6	8	6	97	8	95	8	136	10	134
12/2H71	8	273	10	268	6	87	8	85	8	198	10	194	6	8	6	97	8	95	8	136	10	134
12/2H72	6	290	8	285	4	92	6	91	6	211	8	207	4	6	4	105	6	103	6	145	8	142
12/2H91	4	257	6	252	2	82	4	80	4	185	6	181	2	4	2	90	4	88	4	128	6	126
60 Hz																						
	440-480 V		575-600 V		440-480 V		575-600 V		440-480 V		575-600 V		460 V	575 V	440-480 V		575-600 V		440-480 V		575-600 V	
	S	L1	S	L1	S	L2	S	L2	S	L3	S	L3	S	S	S	L4	S	L4	S	L5	S	L5
	AWG	[ft]	AWG	[ft]	AWG	[ft]	AWG	[ft]	AWG	[ft]	AWG	[ft]	AWG	AWG	AWG	[ft]	AWG	[ft]	AWG	[ft]	AWG	[ft]
12/2H33	12	239	14	235	10	76	12	75	12	171	14	167	10	12	10	81	12	79	12	120	14	118
12/2H42	10	322	12	317	8	102	10	101	12	149	14	146	8	10	10	76	12	74	12	101	14	100
12/2H62	8	334	10	328	6	106	8	104	10	155	12	152	6	8	8	79	10	78	10	105	12	103
12/2H71	8	334	10	328	6	106	8	104	10	155	12	152	6	8	8	79	10	78	10	105	12	103
12/2H72	6	362	8	356	4	115	6	113	8	169	10	166	4	6	6	88	8	86	8	114	10	112
12/2H91	4	295	6	290	2	94	4	92	6	136	8	133	2	4	4	68	6	66	4	148	6	145

Tab. 57

11.3.2 Cable cross sections and lengths of supply cable for pole-changing hoist motors

1 Hoist motor type	2 Stationary Hoist				3 Hoist/crane				4 Hoist/				5 Rising mains max. 33 ft		6 Crane				7 Crane			
	Fixed installation in PVC conduit				Fixed installation in PVC conduit				Festoon cable in free air as flexible PVC-sheathed cable				Fixed installation in PVC conduit		Festoon cable in free air as flexible PVC-sheathed cable				Festoon cable in free air as flexible PVC-sheathed cable			
	Power supply to hoist				Power supply to in-feed (customer's cable to beginning of rising mains)				From end of rising mains to hoist				From main isolator to end of rising mains		From end of rising mains along crane runway to crane control				Power supply along crane bridge to hoist			
	$\Delta U \leq 5\%$				$\Delta U \leq 1\%$				$\Delta U \leq 4\% (4+5)$						$\Delta U \leq 1.5\% (5+6)$				$\Delta U \leq 2.5\%$			
50 Hz																						
	380-415 V		480-525 V		380-415 V		480-525 V		380-415 V		480-525 V		400 V	500 V	380-415 V		480-525 V		380-415 V		480-525 V	
	S	L1	S	L1	S	L2	S	L2	S	L3	S	L3	S	S	S	L4	S	L4	S	L5	S	L5
	AWG	[ft]	AWG	[ft]	AWG	[ft]	AWG	[ft]	AWG	[ft]	AWG	[ft]	AWG	AWG	AWG	[ft]	AWG	[ft]	AWG	[ft]	AWG	[ft]
12/2H73	6	185	8	181	4	59	6	58	6	135	8	132	2	4	4	67	6	66	6	92	8	91
24/4H92	4	153	6	150	1	61	2	76	4	112	6	110	-1	1	1	71	2	88	2	121	4	119
60 Hz																						
	440-480 V		550-600 V		440-480 V		550-600 V		440-480 V		550-600 V		460 V	575 V	440-480 V		550-600 V		440-480 V		550-600 V	
	S	L1	S	L1	S	L2	S	L2	S	L3	S	L3	S	S	S	L4	S	L4	S	L5	S	L5
	AWG	[ft]	AWG	[ft]	AWG	[ft]	AWG	[ft]	AWG	[ft]	AWG	[ft]	AWG	AWG	AWG	[ft]	AWG	[ft]	AWG	[ft]	AWG	[ft]
12/2H73	6	212	8	209	4	68	6	66	8	99	10	97	2	4	4	81	6	79	6	106	8	104
24/4H92	4	176	6	172	1	70	2	87	4	130	6	128	-1	1	1	85	4	66	4	88	6	86

Tab. 58

ba-o.2.6.0-us-1.1-y | A11867501 Rev AA

## 11.4 Tightening torques

**⚠ WARNING**

**Safety hazard.** Unsuitable installation material and incorrect tightening torques may lead to damage and accidents.

- Use only original spare parts.
- Tighten screw connection with a torque spanner to the prescribed tightening torque.

Metric size	Screw grade		
	8.8	10.9	100
	Standard		Y
	Tightening torque [lb <sub>r</sub> ft]		Tightening torque [lb <sub>r</sub> ft]
M6	8	11	-
M8	18	26	-
M10	36	51	55
M12	63	90	64
M16	155	221	184
M20	302	-	-
M24	524	-	-
M30	1040	-	-
M36	1814	-	-

Tab. 59

Values (Y) apply for the attachment of the mounting plate to the gear.

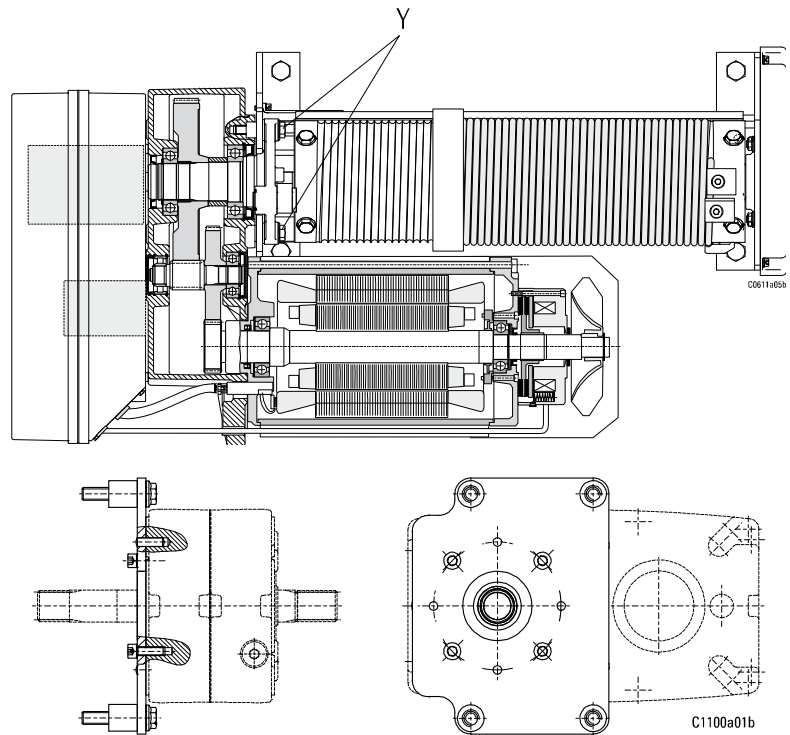

Fig. 106

## Other screw connections and applicable tightening torques

No.	Screw connection Part 1 / Part 2	Wire rope type	Screw connection		
			Metric size	Grade	Tightening torque lbf ft
1	Gear casing/panel box	YKA/SKA – YKB/SKB	M6	8.8	4
2	Gear casing/support plate	YKA/SKA YKB/SKB YKC/SKC	M10 M12 M16	100 100 100	55 64 229
3	Rope drum/gear drive shaft	YKC/SKC	M12	100	96
4	Rope drum/clamping plate	YKA/SKA	M6 / 8	8.8	7 / 18
5	Rope drum bearing journal/holding washer	YKA/SKA YKB/SKB – YKC/SKC YKE/SKE	M8 M10 M16	100	31 55 192
6	Rope drum flange bearing/support plate (fan side)	YKA/SKA YKB/SKB – YKC/SKC YKE/SKE	M8 M10 M16	100	31 55 159
7	Grease pan/guide rail	YKE/SKE	M10	100	55
8	Support plate (fan side)/grease pan	YKA/SKA – YKB/SKB YKC/SKC	M8 M8	C45K S235JR	15 7
9	Support plate (gear side, fan side)/fixing tube (Dg)	YKA/SKA – YKB/SKB	M16	100	243
10	Axle holder/trolley side cheek (hoist side) (kBh-Dg)	YKA/SKA – YKC/SKC (kBh) YKE/SKE (kBh) YKA/SKA – YKB/SKB (Dg) YKC/SKC (Dg)	M8 M8 M8 M8	8.8 100 8.8 100	18 31 15 31
11	Threaded bolt/trolley side cheek (hoist side/counterweight)	YKA/SKA – YKE/SKE	M16	100	159
12	Return pulley bearing plate/bearing pedestal (kBh)	YKE/SKE	M12	100	85
13	Suspension bearing plate/bearing pedestal (kBh)	YKE/SKE	M12	100	85
14	Pivot pin/mounting bracket (Dg)	YKA/SKA – YKC/SKC	M12	8.8	63
15	Pivot pin/pivot pin (Dg)	YKA/SKA – YKC/SKC	M12	8.8	63
16	Guide roller holder/trolley side cheek (Dg)	YKA/SKA – YKC/SKC	M8	100	31

Tab. 60

kBh= underhung low headroom trolley  
 Og= double rail trolley  
 Dg= articulated trolley

# 11 Technical data

## 11.5 Lubricants

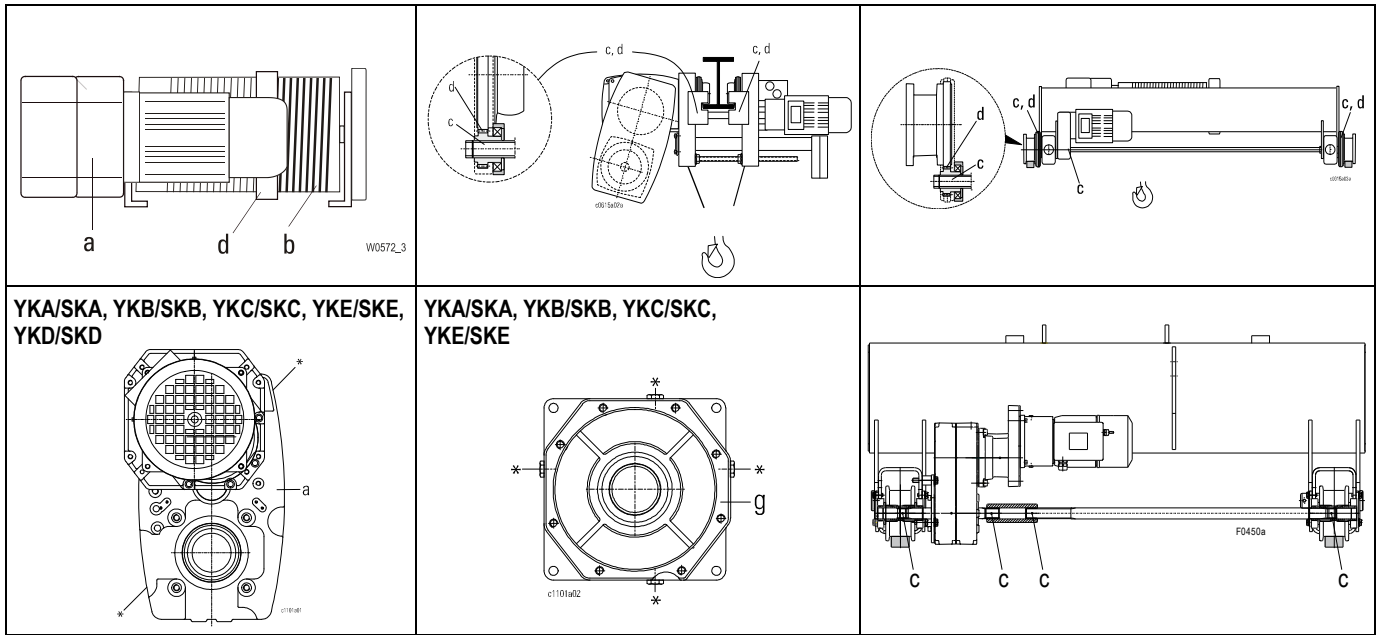

Fig 107

Lubrication point	Type of lubricant	Factory filling (DIN 51502)	Alternative lubricants	Quantity
a	Oil	Fuchs Renolin CLP 460 (Fuchs Renolin Unisyn CLP 220)	- Aral Degol BG 460 Plus - Castrol Alpha SP 460 - Castrol Tribol 1100/460 - Shell Omala S4 WE 320	YKA/SKA: 1.7 qt YKB/SKB: 2.3 qt YKC/SKC: 6.8 qt YKE/SKE: 18.2 qt YKD/SKD: 2.8 qt
b	Grease	Shell Gadus S2 V220 00 KP 2N (Fuchs Renolit RHF1)	- Fuchs Renolit Duraplex EP3 - BP Energrease LS-EP 00 - CENTOPLEX GLP 500	1.3 - 5.5 lb
c	Grease	Mobilux EP 3 (Fuchs Renolit RHF1 GPG 00k)	- Shell Gadus S2 V100 3 - Fuchs Renolit Duraplex EP3 - BP Energrease LS-EP3 - Klüberplex BEM 41-132	3.5 oz
d	Grease	Mobilux EP 3 K3K (Fuchs Renolit RHF1)	- Shell Gadus S2 V100 3 - Fuchs Renolit Duraplex EP3 - BP Energrease LS-EP3 - Klüberplex BEM 41-132	1.1 - 2.2 lb
g	Grease	Fuchs Renolit FLM 0 KPF 0K (Fuchs Renolit RHF1)	- Castrol Viscogen 0 - Klüberplex AG 11-461	YKA/SKA: 3.5 oz YKB/SKB:
	Oil	Fuchs Renolin CLP 460 CLP 460 (Fuchs Renolin Unisyn CLP 220)	- Aral Degol BG 460 Plus - Castrol Alpha SP 460 - Castrol Tribol 110/460 - Shell Omala S4 WE 320	YKC/SKC: 2.8 qt YKE/SKE: 2.8 qt YKD/SKD: 2.8 qt

Tab. 61

- \* Oil filling/oil drainage screw.  
Depending on installation position of gear, the filling screw may be “at the top” and the drainage screw “at the bottom”
- ( ) Synthetic lubricant for operating temperatures -40°F... +104°F
- \*1 YKE/SKE, motor at top

## 11.6 Lubricants for travel drive

See instructions of travel drive.

## 11.7 Circuit diagrams

See separate enclosure.

# WARRANTY

## LIMITATION OF WARRANTIES, REMEDIES AND DAMAGES

### INDEMNIFICATION AND SAFE OPERATION

Buyer shall comply with and require its employees to comply with directions set forth in instructions and manuals furnished by Seller and shall use and require its employees to follow such instructions and manuals and to use reasonable care in the use and maintenance of the goods. Buyer shall not remove or permit anyone to remove any warning or instruction signs on the goods. In the event of personal injury or damage to property or business arising from the use of the goods, Buyer shall within 48 hours thereafter give Seller written notice of such injury or damage. Buyer shall cooperate with Seller in investigating any such injury or damage and in the defense of any claims arising therefrom.

If Buyer fails to comply with this section or if any injury or damage is caused, in whole or in part, by Buyer's failure to comply with applicable federal or state safety requirements, Buyer shall indemnify and hold Seller harmless against any claims, loss or expense for injury or damage arising from the use of the goods.

### CMCO Warranty (HOISTS)

- A.** Columbus McKinnon Corporation ("Seller") warrants to the original end user ("Buyer") that: (a) for a period of one (1) year from the date of Seller's delivery of the goods (collectively, the "Goods") to the carrier, the electrical components of the Goods will be free from defects in workmanship and materials; and (b) for a period of three (3) years from the date of Seller's delivery of the goods (collectively, the "Goods") to the carrier, the mechanical components of the Goods will be free from defects in workmanship and materials.
- B.** IN THE EVENT OF ANY BREACH OF SUCH WARRANTY, SELLER'S SOLE OBLIGATION SHALL BE EXCLUSIVELY LIMITED TO, AT THE OPTION OF SELLER, REPAIR OR REPLACEMENT, F.O.B. SELLER'S POINT OF SHIPMENT, OF ANY GOODS THAT SELLER DETERMINES TO HAVE BEEN DEFECTIVE OR, IF SELLER DETERMINES THAT SUCH REPAIR OR REPLACEMENT IS NOT FEASIBLE, TO A REFUND OF THE PURCHASE PRICE UPON RETURN OF THE GOODS TO SELLER. NO CLAIM AGAINST SELLER FOR ANY BREACH OF (i) SUCH WARRANTY WITH RESPECT TO THE ELECTRICAL COMPONENTS OF ANY GOOD SHALL BE VALID OR ENFORCEABLE UNLESS BUYER'S WRITTEN NOTICE THEREOF IS RECEIVED BY SELLER WITHIN ONE (1) YEAR FROM THE DATE OF SELLER'S DELIVERY TO THE CARRIER AND (ii) SUCH WARRANTY WITH RESPECT TO THE MECHANICAL COMPONENTS OF ANY GOOD SHALL BE VALID OR ENFORCEABLE UNLESS BUYER'S WRITTEN NOTICE THEREOF IS RECEIVED BY SELLER WITHIN ONE (1) YEAR FROM THE DATE ANY ALLEGED CLAIM ACCRUES. EXCEPT FOR THE WARRANTY SET FORTH ABOVE, SELLER MAKES NO OTHER WARRANTIES WITH RESPECT TO THE GOODS, WHETHER EXPRESSED OR IMPLIED, INCLUDING ANY WARRANTIES OF MERCHANTABILITY, FITNESS FOR A PARTICULAR PURPOSE, QUALITY AND/OR THOSE ARISING BY STATUTE OR OTHERWISE BY LAW OR FROM ANY COURSE OF DEALING OR USE OF TRADE, ALL OF WHICH ARE HEREBY EXPRESSLY DISCLAIMED.

**C.** IN NO EVENT SHALL SELLER BE LIABLE TO BUYER OR ANY THIRD PARTY WITH RESPECT TO ANY GOOD, WHETHER IN CONTRACT, TORT OR OTHER THEORY OF LAW, FOR LOSS OF PROFITS OR LOSS OF USE, OR FOR ANY INCIDENTAL, CONSEQUENTIAL, SPECIAL, DIRECT OR INDIRECT DAMAGES, HOWSOEVER CAUSED. SELLER'S MAXIMUM LIABILITY TO BUYER WITH RESPECT TO THE GOODS SHALL IN NO EVENT EXCEED THE PRICE PAID BY BUYER FOR THE GOODS THAT ARE THE SUBJECT OF THE APPLICABLE CLAIM.

**D.** Seller shall not be liable for any damage, injury or loss arising out of the use of the Goods if, prior to such damage, injury or loss, such Goods are: (1) damaged or misused following Seller's delivery to the carrier; (2) not maintained, inspected, or used in compliance with applicable law and Seller's written instructions and recommendations; or (3) installed, repaired, altered or modified (a) with any part or accessory other than those supplied by Seller or (b) without compliance with such laws, instructions or recommendations.

**E.** This warranty is limited and provided only to the original end user. Each Good must be registered within sixty (60) days of receipt of each product to establish eligibility. Please register at [www.cmworks.com/hoist-warranty-registration](http://www.cmworks.com/hoist-warranty-registration) or submit registration card via US mail.

**F.** Any action against Seller for breach of warranty, negligence or otherwise in connection with the electrical components of any Good must be commenced by Buyer within one (1) year after: (a) the date any alleged claim accrues; or (b) the date of delivery of the Goods to Buyer, whichever is earlier. Any action against Seller for breach of warranty, negligence or otherwise in connection with the mechanical components of any Good must be commenced by Buyer within one (1) year after the date any alleged claim accrues.

**G.** This warranty is contingent upon Buyer's proper maintenance and care of the Goods, and does not extend to normal wear and tear. Seller reserves the right, at its option, to void this warranty in the event of Buyer's use with the Goods of parts or accessories other than those supplied by Seller.

### **WARNING**

**Alterations or modifications of equipment and use of non-factory repair parts can lead to dangerous operation and injury.**

**TO AVOID INJURY:**

- Do not alter or modify equipment.
- Do use only factory replacement parts.



FAMILY OF BRANDS



**USA:** Ph: (800) 888.0985 • (716) 689.5400 • Fax: (716) 689.5644 • [www.cmworks.com](http://www.cmworks.com)

**CANADA:** Ph: (877) 264.6478 • Fax: (877) 264.6477 • [www.cmworks.com](http://www.cmworks.com)